

PAPER • OPEN ACCESS

Prediction of population growth using Sugeno and Adaptive Neuro-Fuzzy Inference System (ANFIS)

To cite this article: A H S Jones *et al* 2018 *IOP Conf. Ser.: Mater. Sci. Eng.* **403** 012073

View the [article online](#) for updates and enhancements.

ECS
The Electrochemical Society
THE KOREAN ELECTROCHEMICAL SOCIETY

The best technical content in electrochemistry and solid state science and technology!

Available until November 9, 2020.

PRIME™
PACIFIC RIM MEETING
ON ELECTROCHEMICAL
AND SOLID STATE SCIENCE
2020

REGISTER TO ACCESS CONTENT FOR FREE! ▶

Prediction of population growth using Sugeno and Adaptive Neuro-Fuzzy Inference System (ANFIS)

A H S Jones¹, A Pranolo², A Dianto³ and S Winiarti⁴

Department of Informatics, Universitas Ahmad Dahlan University, Indonesia

¹annahendri@tif.uad.ac.id, ²andri.pranolo@tif.uad.ac.id, ³agusdianto92@gmail.com,

⁴sri.winiarti@tif.uad.ac.id

Abstract. Government use population growth data to design sustainable policies frameworks. This research aims to predict the population growth using adaptive neuro-fuzzy inference system (ANFIS) and Sugeno as comparison method. The ANFIS consists of determining layers (1 to 5), system design, implementation, and system testing stage. The results of using ANFIS is 0.44% while prediction test of using Sugeno is 16,09% in year 2010. The Sugeno result is categorized as a negative growth since it is far up from the ideal rate set by the government of 0.5% per year.

1. Introduction

Indonesian government held the population census in every 10 years. Census data is the primary data, used by social, economic, and demographic planners. ANFIS (adaptive neural fuzzy inference system) combined the of fuzzy inference system and neural network adaptive learning ability, which used for optimization, data mining, selection multi criteria, and prediction [1-6].

The selection of the methods was taking based on previous works reported by Oprea *et al.* [4] who used ANFIS as an internal fuzzy rule base in a prediction. When rule base is empty, ANFIS generates the rules and adjust the FIS parameters to match the input output datasets. The results are compared with data mining technique and evaluated by RMSE, MAPE, and simulation time. ANFIS has a small value of RMSE which is indicates that ANFIS is better in prediction than another technique in this research. This is corroborated by Zhang and Lei [7] who reported that ANFIS convergence speed is faster and predictive values are in conformity with the measured values in the case of prediction of laser cutting roughness. In many cases, ANFIS are combined with several methods such as ANFIS-Genetic Algorithm, ANFIS-Differential evolution, ANFIS-particle swarm optimization [8]. ANFIS result is depend on selection of optimization method in training [5].

This research will predict the population growth using a computer based system. The method used in this research are Adaptive Neuro Fuzzy Inference System (ANFIS) to determine the prediction of growth rate of the inhabitants of the per year, where Sugeno [9, 10] is used as a baseline method. This research is designed to ease the government to predict the annual of population growth. The data retrieves from the Central Bureau of the Republic of Indonesia with population census period of 1961, 1971, 1980, 1990, 2000, 2010.



2. Method

2.1. Adaptive Neuro Fuzzy Inference System

Adaptive Neuro Fuzzy Inference System (ANFIS) is a combination of artificial neural networks and fuzzy logic. Fuzzy inference systems trained using artificial neural network systems. Thus, the hybrid possesses all advantages of artificial neural network systems and fuzzy inference systems. From its ability to learn, the neuro-fuzzy system is often referred as adaptive neuro fuzzy inference systems (ANFIS). One of the most well-known structures is the fuzzy inference of the Takagi-Sugeno-Kang model [9, 10], is shown in figure 1.

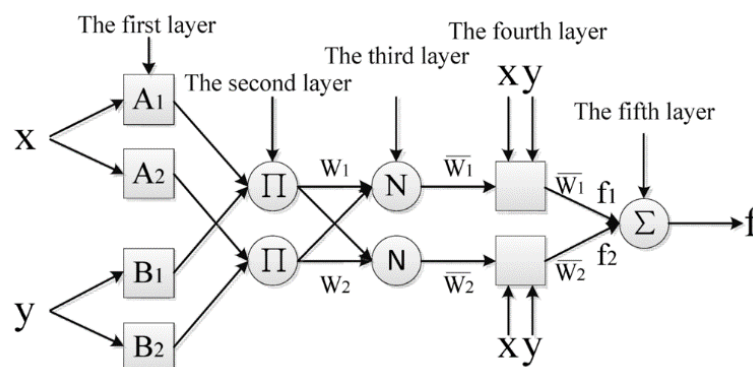

Figure 1. ANFIS structure.

In the Neuro-Fuzzy system, there are five layers of process fuzzification (1st Layer), production (2nd layer), normalization (3rd layer), defuzzification (4th layer), and summarization (5th layer) [10-12].

2.2. Sugeno methods

Fuzzy sugeno is a fuzzy inference technique which can be seen as the form of IF – THEN rules, where the output is a linear equation or constant values [9]. The Sugeno model uses the Singleton membership function that is a membership function that has a membership degree of 1 on a single crisp value and 0 on another crisp value [10].

a. Fuzzy Sugeno Orde-Zero

In general, the form of fuzzy model Sugeno Orde zero is shown in equation (1).

$$\text{IF } (X_1 \text{ is } A_1) \circ (X_2 \text{ is } A_2) \circ \dots \circ (X_n \text{ is } A_n), \text{ then } z = k \quad (1)$$

where A_i is the set of fuzzy to- i as antecedents and k is a constant as a consequence.

b. Model Fuzzy Sugeno Orde-One

In general, the form of fuzzy model Sugeno Orde one is shown in equation (2).

$$\text{IF } (X_1 \text{ is } A_1) \circ (X_2 \text{ is } A_2) \circ \dots \circ (X_n \text{ is } A_n) \text{ THEN } z = p_1 * X_1 + p_2 * X_2 + \dots + p_n * X_n = q \quad (2)$$

where A_i is the set of fuzzy to- i as antecedents and p_i is a constant to i and q is also a constant in consequence.

3. Results and discussion

3.1. ANFIS

The ANFIS of population growth in Sleman regency – Indonesia as data sample is shown in equation (3). Where $\mu A(x)$ is degree of membership, x is population of census data, c is standard deviation, a is mean, and y, z are census time.

$$\mu_a(x) = \frac{1}{1 + \left| \frac{x-c}{x} \right|^{2b}} \quad (3)$$

Based on figure 1 can be describes the process for each layer. The first layer, fuzzy layer, converts inputs into a fuzzy set by means of membership functions (MFs). It contains adaptive nodes, that can be seen in table 1.

Table 1. 1st layer.

Data	Y		Z	
	X1	X2	X1	X2
1	516,653	588,313		
2	588,313	677,323		
3			677,323	780,334
4	780,334	901,377		
5			901,377	1,093,110
Mean	628,433.3	722,337.6	789,350	936,722
Standard deviation	64,272.2	76,043.2	79,215.0	110,583.0

From table 1, The fuzzy set by MFs can be find by using describe as $\mu_{A_1}(x) = \frac{1}{1 + \left| \frac{x-628433,3}{64272,2} \right|^2}$, $\mu_{A_2}(x) = \frac{1}{1 + \left| \frac{x-722337,6}{76043,2} \right|^2}$, $\mu_{B_1}(x) = \frac{1}{1 + \left| \frac{x-789350}{79215,0} \right|^2}$, and $\mu_{B_2}(x) = \frac{1}{1 + \left| \frac{x-936722}{110583,0} \right|^2}$. The result shows various forms of membership function for fuzzy set A. The parameters in this layer are called premise parameters which degree of its membership can be seen in table 2.

Table 2. Degree of membership.

Data	Degree of Membership			
	μ_{A_1}	μ_{A_2}	μ_{B_1}	μ_{B_2}
1	0.248465	0.243529	0.077817	0.091520
2	0.719602	0.740514	0.134395	0.153787
3	0.633468	0.632245	0.333333	0.333333
4	0.151846	0.152828	0.987211	0.907310
5	0.052537	0.040366	0.333333	0.333333

In the 2nd layer, every node is a fixed node, with the function node to be multiplied by input signals to serve as output signal as shown in equation (4).

$$W_1 = \mu_{A_1}(x) * \mu_{B_1}(x); W_2 = \mu_{A_2}(x) * \mu_{B_2}(x) \quad (4)$$

where W_1 and W_2 are *firing-strength*, $\mu_{A_1}(x)$ is degree of membership of set Y, $\mu_{B_1}(x)$ is degree of membership of set Z. The 2nd layer results can be seen in table 3.

Table 3. 2nd Layer result.

Data	Output 2 nd layer	
	W_1	W_2
1	0.019335	0.022288
2	0.096711	0.113882
3	0.211156	0.210748
4	0.149904	0.138662
5	0.017512	0.013455

Every node in 3rd layer is considered a fixed node, marked by a circle and labelled by N , with function node to normalize the firing strength by computing the ratio of the node firing strength to sum of all firing strength rules by using equation (5).

$$\bar{w} = \frac{w_1}{w_1+w_2} ; \quad \bar{w} = \frac{w_2}{w_1+w_2} \quad (5)$$

where \bar{w} is normalized firing strength, w_1 and w_2 are the output of 2nd layer. The quantity \bar{w} is known as the normalised firing strength. The output of 3rd layer can be seen in table 4.

Table 4. Normalized firing strength.

Data	Output layer 3	
	\bar{w}_1	\bar{w}_2
1	0.464527	0.535473
2	0.459233	0.540767
3	0.500483	0.499517
4	0.519478	0.480522
5	0.565501	0.434499

The output of the parameter coefficients can be seen in table 5.

Table 5. The parameter coefficients.

Data	Parameter coefficients					
	p_1	q_1	r_1	p_2	q_2	r_2
1	0.929053	1.858106	0.464527	2.677367	13.386836	0.535473
2	0.918465	1.836931	0.459233	2.703837	13.519184	0.540767
3	1.000966	2.001932	0.500483	2.497585	12.487924	0.499517
4	1.038956	2.077913	0.519478	2.402609	12.013046	0.480522
5	1.131002	2.262003	0.565501	2.172496	10.862481	0.434499

In the 4th layer, every node is an adjustable node, marked by a square, with node function as in equation (6).

$$o_{4,i} = \bar{w}_i \cdot f_i = \bar{w}_i(p_i x + q_i x + r_i) \quad (6)$$

where p_i , q_i and r_i are the parameters set, referred to as the consequent parameters.

The last process is finding w_i and y_i for summarization process, $y' = \sum \bar{w}_i y_i = \bar{w}_1 y_1 + \bar{w}_2 y_2$, in 5th layer which can be shown in table 6.

Table 6. Output of 4th and 5th layer.

Data	4 th Layer		5 th Layer
	$\bar{w}_1 y_1$	$\bar{w}_2 y_2$	$\sum \bar{w}_i y_i$
1	10.822204	184.717673	195.539877
2	10.582174	188.275869	198.858043
3	12.523681	161.447750	173.971430
4	13.472641	149.786203	163.258845
5	15.915474	123.342183	139.257657

After finding the 5th layer, the data will be processed under normal circumstances, thus we need to normalize it by using equation (7).

$$result = \left(\frac{a_1}{L_5}\right) + a_1 \quad (7)$$

where a_1 is population growth data, and L_5 is output of 5th layer. The results of long-term population forecasts normalization which is conducted using ANFIS, then it compared with the actual data from 1961 to 2000 (table 7).

Table 7. Comparison results between real data of population and ANFIS.

Data	Year	Population	ANFIS	Error
1	1961	516,653	519,295	0.51%
2	1971	588,313	590,911	0.44%
3	1980	677,323	680,292	0.44%
4	1990	780,334	783,498	0.41%
5	2000	901,377	905,087	0.41%
Average				0.44%

3.2. Sugeno

In this research, Fuzzy Sugeno method will be used as a comparison. The steps of Sugeno method can be described as:

- 1) Establishment of membership for Increase function and decrease Function (figure 2).

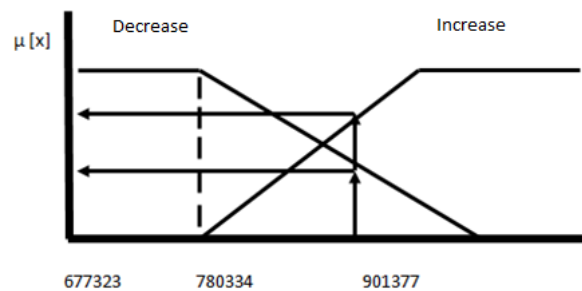

Figure 2. Decrease and Increase Degree of membership function.

Degree of membership value from decrease function and increase function, can be calculated as μ_{ptmbh} Decrease [780334] = $\frac{901377-780334}{224054} = 0.54$, and μ_{ptmbh} Increase [780334] = $\frac{780334-677323}{224054} = 0.46$.

- 2) Establishment of membership for Few function and many Function (figure 3).

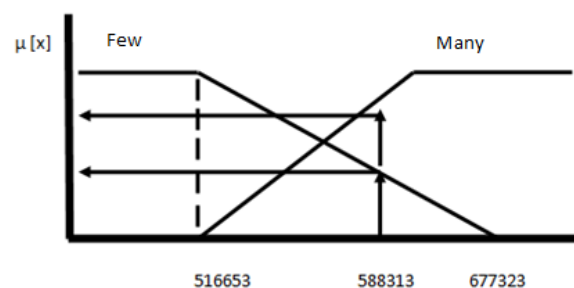

Figure 3. Decrease and Increase Degree of membership function.

Degree of membership value from few function and many function can be calculated as μ_{ptmbh} Few [588313] = $\frac{677323-588313}{160670} = 0.56$, and μ_{ptmbh} Many [588313] = $\frac{588313-516653}{160670} = 0.44$. Some possible rules which possible can be created by Sugeno for the experimental data, and the population created by Sugeno can be seen in table 8, and the error of prediction of Sugeno is 16.09% (higher than 3%).

Table 8. Comparison of Sugeno and real data population (year 2010).

Real data population	Sugeno
1,093,110	1,269,064

Based on the calculation of Sleman growth rate prediction, it can be said that there is a negative growth due to the occurrence of spike and increase of population equal to 16.09%. This result far from ideal rate which has been set by government which equal to 0.5% per year.

4. Conclusion

The result of population growth prediction is 0.44% from census data, while the prediction data of population growth using Sugeno method is 16.10%. Based on this result, the Sugeno method resulted in negative growth predictions, meaning that this result is far from the tolerance of government prediction that is only 0.5% per year.

References

- [1] Yousefi M, Hooshyar D, Remezani A, Sahari K S M, Khaksar W and Alnaimi F B I 2015 Short-term wind speed forecasting by an adaptive network-based fuzzy inference system (ANFIS): an attempt towards an ensemble forecasting method *Int. J. Adv. Intell. Informatics* vol 1 no 3 pp 140–9
- [2] Munandar D 2017 Wavelet discrete transform, ANFIS and linear regression for short-term time series prediction of air temperature *Int. J. Adv. Intell. Informatics* vol 3 no 2 pp 68–80
- [3] Mohan A, Kuchhal P and Sharma M G 2017 Prediction Models for Global Solar Radiations, Diffused Radiations and Direct Solar Radiations Using ANFIS *Proceeding of International Conference on Intelligent Communication, Control and Devices* pp 27–37
- [4] Oprea M, Popescu M, Mihalache S F and Dragomir E G 2017 Data Mining and ANFIS Application to Particulate Matter Air Pollutant Prediction. A Comparative Study *ICAART (2)* pp 551–8
- [5] Tabrizi S S and Sancar N 2017 Prediction of Body Mass Index: A comparative study of multiple linear regression, ANN and ANFIS models *Procedia Comput. Sci.* vol 120 pp 394–401
- [6] Wang J-S and Ning C-X 2015 ANFIS Based time series prediction method of bank cash flow optimized by adaptive population activity PSO algorithm *Information* vol 6 no 3 pp 300–13
- [7] Zhang Y and Lei J 2017 Prediction of Laser Cutting Roughness in Intelligent Manufacturing Mode Based on ANFIS *Procedia Eng.* vol 174 pp 82–9
- [8] Chen W, Panahi M and Pourghasemi H R 2017 Performance evaluation of GIS-based new ensemble data mining techniques of adaptive neuro-fuzzy inference system (ANFIS) with genetic algorithm (GA), differential evolution (DE), and particle swarm optimization (PSO) for landslide spatial modelling *Catena* vol 157 pp 310–24
- [9] Zeng W, Zhao Y and Yin Q 2016 Sugeno fuzzy inference algorithm and its application in epicentral intensity prediction *Appl. Math. Model.* vol 40 no 13–14 pp 6501–08
- [10] Sugeno M and Kang G T 1988 Structure identification of fuzzy model *Fuzzy sets Syst.* vol 28 no 1 pp 15–33
- [11] Noori R, Safavi S and Shahrokni S A N 2013 A reduced-order adaptive neuro-fuzzy inference system model as a software sensor for rapid estimation of five-day biochemical oxygen demand *J. Hydrol.* vol 495 pp 175–85
- [12] Ahmed A A M and Shah S M A 2017 Application of adaptive neuro-fuzzy inference system

(ANFIS) to estimate the biochemical oxygen demand (BOD) of Surma River *J. King Saud Univ. Sci.* vol 29 no 3 pp 237–43