

## Internet of things with NodeMCU ESP8266 for MPX-5700AP sensor-based LPG pressure monitoring

Tole Sutikno<sup>1,3</sup>, Muhamad Haikal Ar-Rasyid<sup>2</sup>, Tri Wahono<sup>1,3</sup>, Watra Arsadiando<sup>3</sup>

<sup>1</sup>Master Program of Electrical Engineering, Faculty of Industrial Technology, Universitas Ahmad Dahlan, Yogyakarta, Indonesia

<sup>2</sup>Department of Electrical Engineering, Faculty of Industrial Technology, Universitas Ahmad Dahlan, Yogyakarta, Indonesia

<sup>3</sup>Embedded System and Power Electronics Research Group, Yogyakarta, Indonesia

### Article Info

#### Article history:

Received Dec 7, 2022

Revised Aug 24, 2023

Accepted Sep 1, 2023

#### Keywords:

Blynk application

Internet of things

Liquefied petroleum gas (LPG)

MPX-5700AP sensor

NodeMCU ESP8266

### ABSTRACT

The use of liquefied petroleum gas (LPG) cylinders as fuel has become a basic need for the community. LPG is more efficient than oil stoves, but LPG also poses a danger. The dangers contained in gas cylinders cause users to be afraid to check the availability of gas in cylinders because the checking process must be directly close to the gas cylinder. Because of this danger, users do not check gas availability, causing it to run out of gas when cooking. To solve this problem, a system is needed to detect the availability of LPG contents, which can be monitored remotely so that users will feel safe because they are not close to gas cylinders. The condition of gas cylinder availability can be remotely monitored using the internet of things (IoT) method. Therefore, an IoT-based LPG pressure monitoring tool was designed. A tool designed using the MPX-5700AP sensor is useful for detecting gas pressure values in LPG cylinders. IoT is used to monitor LPG pressure using the Blynk application. The buzzer module is a tool for sending sound signals as information on the condition of gas cylinders. The NodeMCU ESP8266 microcontroller processes and sends data to the Blynk application. System testing is carried out in three conditions: full, close to empty, and empty. The results of this test showed an error value of 3.41% and an accuracy rate of 96.59%.

This is an open access article under the [CC BY-SA](https://creativecommons.org/licenses/by-sa/4.0/) license.



### Corresponding Author:

Tole Sutikno

Master Program of Electrical Engineering, Faculty of Industrial Technology, Universitas Ahmad Dahlan

Ring Road Selatan, Tamanan, Banguntapan, Bantul, Yogyakarta 55166, Indonesia

Email: tole@te.uad.ac.id

## 1. INTRODUCTION

The Indonesian government launched a program to convert kerosene to liquefied petroleum gas (LPG) fuel starting in 2007 most Indonesian families cook their meals using LPG. Due to various factors, including high cooking efficiency, clean flame, and simplicity of storage and delivery. Besides the benefits of LPG, it can also be hazardous for its users, which causes many to fear the dangers of LPG exploding. To see the availability of gas cylinder contents, you have to look directly at the gas cylinder regulator. However, certain issues come up for those who use LPG cylinders, such as not knowing how much gas is left in the bottle during use because the tube is opaque and being aware of gas leaks, which might jeopardize users' safety [1]. In this approach, a sudden stop in the tube's contents might obstruct food preparation and result in unanticipated costs to the family budget because leaks can seriously harm those who use LPG cylinders. This is what causes people to be reluctant to see the contents of the gas, causing the gas to run out when used suddenly. Running out of gas during cooking will result in delays in the cooking process. Placement of gas cylinders adjacent to the stove certainly increases the risk of accidents that can endanger the lives of LPG

users. Besides the benefits of LPG, it can also be hazardous for its users, which causes many to fear the dangers of LPG exploding. To see the availability of gas cylinder contents, you have to look directly at the gas cylinder regulator. However, certain issues come up for those who use LPG cylinders, such as not knowing how much gas is left in the bottle during use because the tube is opaque and being aware of gas leaks, which might jeopardize users' safety. In this approach, a sudden stop in the tube's contents might obstruct food preparation and result in unanticipated costs to the family budget because leaks can seriously harm those who use LPG cylinders. This is what causes people to be reluctant to see the contents of the gas, causing the gas to run out when used suddenly. Running out of gas during cooking will result in delays in the cooking process. Placement of gas cylinders adjacent to the stove certainly increases the risk of accidents that can endanger the lives of LPG users.

The condition of the gas pressure in the LPG cylinder will undoubtedly change as the gas is used for cooking or other things. The regulator is a tool that can see the pressure value of the gas cylinder. However, the function of the regulator still requires the user to be directly close to the LPG gas cylinder to see the pressure value in the cylinder [2], [3]. Therefore, a tool is designed to monitor gas pressure conditions remotely so that users do not need direct contact with LPG gas cylinders. Therefore a tool is designed to monitor gas pressure conditions remotely so that users do not need direct contact with LPG gas cylinders. In today's advanced era, people can easily activate and deactivate something without direct contact with the object. The public can also monitor something without looking directly at it. The internet of things (IoT) [4]–[8] works by utilizing a programming argument, where each program command can produce an interaction between the microcontroller and other devices [4], [5], [7], [9], [10]. IoT devices have been automatically connected without human intervention and without regard for distance [3], [11]–[13]. IoT can be used to monitor a device or an object remotely [3], [13], for example, by monitoring gas pressure conditions. IoT technology can be accessed using microcontrollers, including Arduino, NodeMCU, and STM32 [14]–[17]. The research was designed as a gas pressure monitoring tool using the MPX-5700AP sensor. The study used the MPX-5700AP sensor; the sensor readings were compared with a digital pressure gauge to test the sensor's ability to apply 3 kg LPG gas. The gas cylinder is monitored by flowing gas pressure to the pressure sensor. Gas pressure values are sent using the NodeMCU ESP8266 microcontroller. The tool is equipped with a buzzer module as a notification indicator on the system.

## 2. RESEARCH METHOD

In this study, a device is created that can monitor LPG pressure using the IoT approach and the Blynk application. The MPX-5700AP sensor, which transforms a pressure measurement to a voltage [18]–[21], is employed in this tool. A pressure sensor that can read the air pressure in the manifold, is a pressure sensor that has a six-pin package. The sensor outputs an analog-level output signal accurately proportional to the applied pressure. at 0 to 85 °C has a pressure range from 15 Kpa to 700 Kpa. supply voltage range from 4.75 VDC to 5.25 VDC and operating temperature range -40 to 125 °C [22]. This sensor can collect data from the observed LPG pressure. The sensor's data is then shown on the Blynk application, allowing users to determine whether the gas cylinder is still full, close to empty and empty.

### 2.1. Experimental setup

Several materials and research materials are required for the design of an IoT-based LPG pressure prototype [23]. Figure 1 depicts a block diagram of the overall system. The primary gas pressure sensor is the MPX-5700AP.

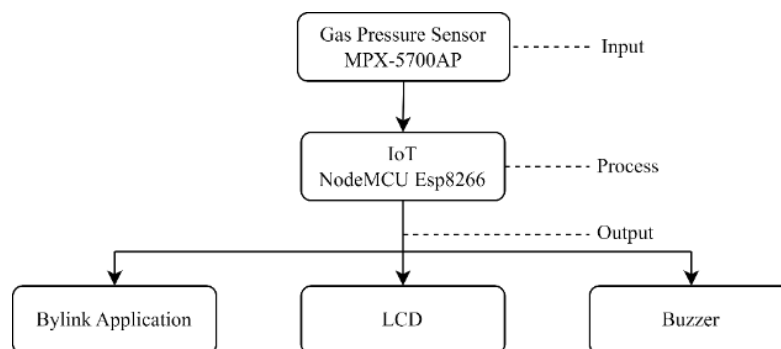

Figure 1. Block diagram of the LPG pressure monitoring system

In real-time, the pressure sensor provides conditions for the contents of gas cylinders. The obtained data is then sent to the NodeMCU microcontroller [24]–[26]. The microcontroller, which receives a voltage supply from the power supply, will process the gas pressure data obtained from the MPX-5700AP gas pressure sensor. The microcontroller's processed data is sent to the Blynk application; the LCD serves as a data display; and the buzzer serves as an output in the form of a warning. This system employs the MPX-5700AP sensor [27], which receives input from LPG pressure and sends data to the NodeMCU, which notifies the Blynk application [20], [26], [28], [29], displays the value on the LCD, and then sounds a buzzer as an indicator of gas pressure condition [19], [21]. Figure 2 shows the LPG gas pressure monitoring system, Figure 2(a) shows the wiring diagram, and Figure 2(b) shows the hardware experimental setup.

## 2.2. LPG gas monitoring system flowchart

The MPX-5700AP gas pressure sensor's measurement of the gas pressure serves as the system's primary parameter in this study. Measurement results are displayed on the liquid crystal display (LCD) screen and can be monitored remotely with the Blynk application [30]–[32]. The LPG monitoring system flow diagram is presented in Figure 3.

The system is designed to monitor LPG pressure. The NodeMCU microcontroller [8], [9], [33]–[36] then processes the pressure value from the LPG cylinder read by the pressure sensor. If the pressure value in Figure 3 is 5 psi, then the green LED indicator on the Blynk application lights up. The Light-emitting diode (LED) indicator indicates that the LPG cylinder is full, and the buzzer does not light up. If the LPG pressure sensor value is between 1 and 5 psi, the orange LED on the Blynk application lights up. The indicator indicates that the contents of the LPG cylinder are almost depleted, as marked by a paused buzzer sound. If the pressure value is already at 0 psi, then the red LED indicator on the Blynk application lights up, and the buzzer continues to sound. So, it is necessary to replace or fill the gas cylinder.

## 3. RESULTS AND DISCUSSION

This test is carried out by measuring the input and output voltages on the system. After designing the hardware for an IoT-based LPG pressure monitoring system, including the MPX-5700AP pressure sensor, Blynk application, 16x2 LCD, and NodeMCU microcontroller, the hardware was assembled into a system. All components installed according to a predetermined holder and connected to each element using a cable can be seen in Figure 2(b). This system board does not use buttons for settings. The system runs automatically, reading the results of the reading of the gas pressure value when it is electrified and connected to a sensor with a 5 volt voltage source.

### 3.1. MPX-5700AP sensor testing

The first test is the MPX-5700AP sensor, which is tested on the Arduino IDE software using a NodeMCU microcontroller, which will display the gas pressure value on the Arduino IDE serial monitor. After the MPX-5700AP sensor can be used to compare the value of the MPX-5700AP sensor with the digital pressure gas. Furthermore, gas pressure comparison data was taken from a 3 kg LPG cylinder regulator, which had adjusted the pressure to 700 Kpa. This has been adjusted to the maximum limit of the MPX-5700AP sensor specifications. Then, the regulator is connected to an MPX-5700AP sensor and a digital pressure gauge.

The tested variable of the pressure sensor is compared with the pressure value of the digital pressure gauge. The difference is calculated from the reference value minus the sensor value. The difference is divided by the reference value multiplied by 100% to calculate the error percentage. The error value of the MPX-5700AP sensor can be calculated using (1) while determining the percentage of error values using (2). A comparison of MPX-5700AP sensor pressure and digital pressure gauge yields an error value of 8.14%, as shown in Table 1.

This demonstrates that the MPX5700AP sensor's sensor readings converted to Kpa have an accuracy of 91.86%. The error value of the MPX-5700AP sensor obtained has not been adjusted to the program parameters we use.

$$\text{Difference} = |\text{reference value} - \text{sensor value}| \quad (1)$$

$$\text{Error percentage} = \frac{|\text{difference}|}{|\text{reference value}|} \times 100\% \quad (2)$$



Figure 2. The LPG gas pressure monitoring (a) wiring diagram, and (b) hardware experimental setup

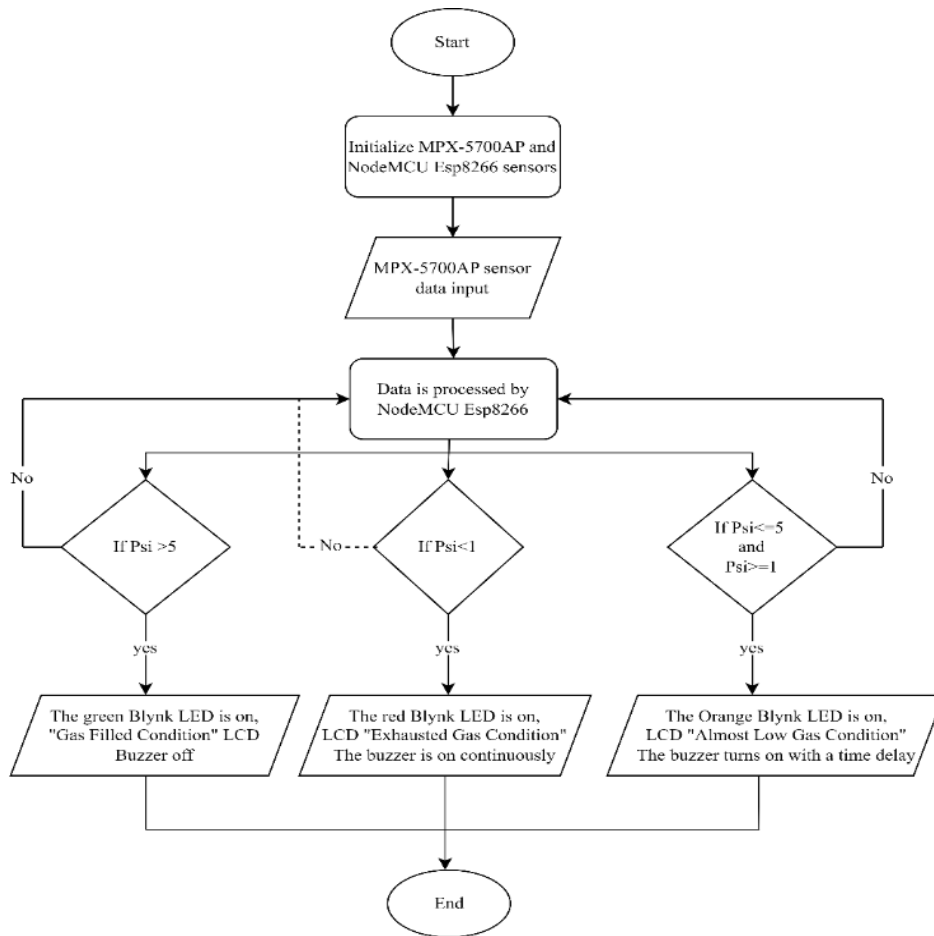

Figure 3. Flowchart of the LPG monitoring system

Table 1. MPX-5700AP pressure sensor values

No.	MPX-5700AP (Kpa)	Digital compressor (Kpa)	Error (%)
1	645	700	7.85
2	657	700	6.14
3	655	700	6.42
4	582	650	10.46
5	579	650	10.92
6	601	650	7.53
7	563	600	6.16
8	542	600	9.66
9	537	600	10.5
10	518	550	5.81
Average error			8.14

**3.2. Internet of things (IoT) testing**

The Blynk application was used in this study as a platform. This IoT test will evaluate Blynk's ability to receive data. The pressure value measured by the MPX-5700AP sensor is sent as data. In Blynk, the data display is in the form of numeric values, making it easy for readers to understand. This graph illustrates the sensor output value in units of Kpa. Pressure data can be downloaded in real-time as well. Figure 4 shows Blynk's display.

Figure 4(a) shows the Blynk application with a pressure value of 657 Kpa. On the monitor screen, it can be seen that the green LED indicator lights up on the full indication. Figure 4(b) depicts the next Blynk view, showing the application of Blynk with a rated pressure of 500 Kpa. The value shows that the orange LED lights up, indicating that the gas is close to empty. Figure 4(c) shows the application of Blynk at 50 Kpa. At this value, the LED indicator lights up red, indicating that the contents of the gas cylinder are empty.

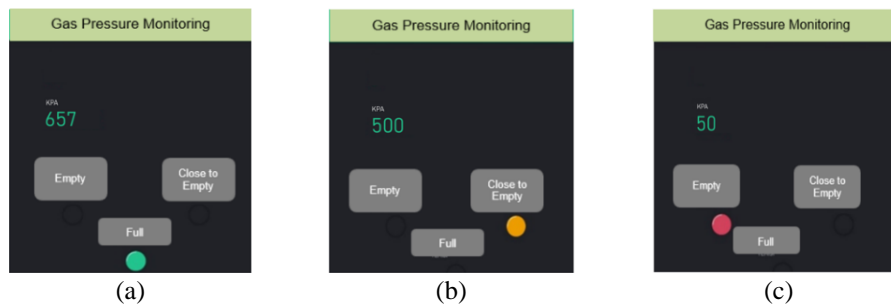

Figure 4. Blynk application display indicators, (a) full, (b) close to empty, and (c) empty

**3.3. LPG gas pressure detection monitoring**

The system is intended for 3 kg LPG cylinders to determine whether or not the system is functioning properly. The pressure limit of LPG was used in this study to conduct testing. This test is performed when the gas pressure conditions are full, close to empty, or empty. The results of the gas pressure test were carried out ten times. The gas pressure values range between 657, 655, 563, and 518 Kpa. In this condition, the Blynk application displays a green LED flame. This indicates that the gas cylinder is full. The gas pressure ranges between 500, 415, and 243 Kpa for the following conditions. In this condition, the Blynk application displays an orange LED flame. Indicates that the condition of the gas cylinder is close to empty. The gas pressure value ranges between 50, 30, and 20 Kpa for the empty gas cylinder content indicator. In this condition, the Blynk application displays a red LED flame.

Table 2 shows the results of the system test data. In this test, the Kpa unit is used to test gas starting from full, close to empty, and empty conditions. From this test, an error value of 3.41% was obtained. Research conducted by [22], [37] that the test was carried out using maximum pressure sensor data of 97.37 Kpa, which resulted in an error value of 3.92% and an accuracy of 96.08%. In this study, the maximum pressure sensor data of 657 Kpa resulted in an average error of 3.41%. Shows that the designed tool has an accuracy of 96.59%. Figure 5 shows a graph of LPG pressure values in a full tank until empties. The chart shows that the pressure value obtained by the system is not much different from the pressure value received by the digital pressure gauge. This pressure data is stated in Kpa units. The graph shows the most minor error when the gas pressure value at 500 Kpa is close to empty. The sensor reading has a zero percent error rate in an empty condition. The lower the pressure, the higher the accuracy of the sensor increases.

Table 2. The results of the system test data

No.	System pressure (Kpa)	Digital pressure gauge (Kpa)	Indicator	Blynk LED	Error (%)
1	657	700	Full	Green	6.14
2	655	700	Full	Green	6.42
3	563	600	Full	Green	6.16
4	518	550	Full	Green	5.81
5	500	500	Close to empty	Orange	0
6	415	445	Close to empty	Orange	6.77
7	243	250	Close to empty	Orange	2.80
8	50	50	Empty	Red	0
9	30	30	Empty	Red	0
10	20	20	Empty	Red	0
Average error					3.41

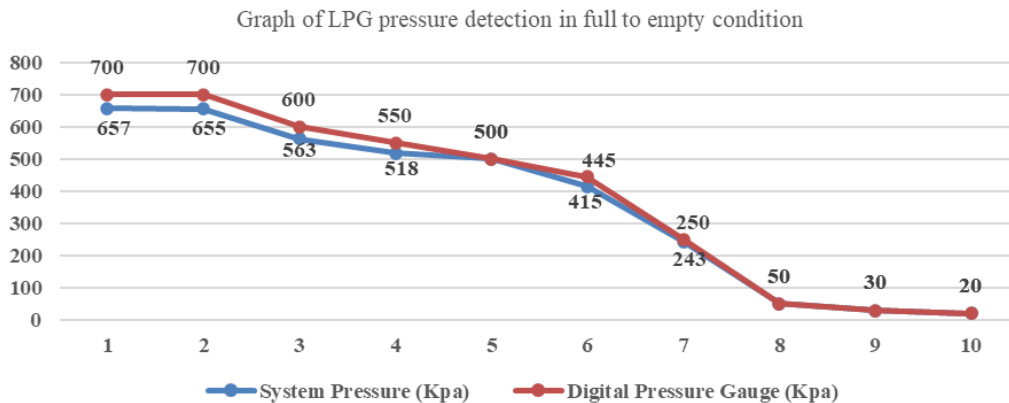

Figure 5. Graph of LPG pressure detection in full to empty condition

#### 4. CONCLUSION

The IoT can be used to develop LPG pressure detection monitoring systems, which can then be used to obtain accurate test results by basing those results on the findings of an IoT-based pressure monitoring system. It is possible to connect the MPX-5700AP pressure sensor to NodeMCU to read the pressure value. Once the value has been read, it can be displayed on the LCD and sent to the Blynk application. The system can send notifications using a buzzer to provide information about the conditions of gas pressure, such as when the gas is full, close to empty, and empty. From the results of the tests, the error value was 3.41%, and the accuracy value was 96.59%.

#### ACKNOWLEDGEMENTS



We would like to express our gratitude to the Embedded Systems and Power Electronics Research Group (ESPERG), which has been of tremendous assistance to us in our scientific work. In addition, we would like to extend our gratitude to the members of ESPERG who contributed to the successful completion of this research.

#### REFERENCES



- [1] G. V. D. S. Medeiros, M. R. D. Santos, A. S. B. Lopes, and E. C. B. Neto, "Smartgas: a smart platform for cooking gas monitoring," in *2017 IEEE First Summer School on Smart Cities (S3C)*, Aug. 2017, pp. 97–102, doi: 10.1109/S3C.2017.8501387.
- [2] V. Mariselvam and M. Siva Dharshini, "IoT based level detection of gas for booking management using integrated sensor," *Materials Today: Proceedings*, vol. 37, pp. 789–792, 2021, doi: 10.1016/j.matpr.2020.05.825.
- [3] A. Varma, Prabhakar S, and K. Jayavel, "Gas leakage detection and smart alerting and prediction using IoT," in *2017 2nd International Conference on Computing and Communications Technologies (ICCT)*, Feb. 2017, pp. 327–333, doi: 10.1109/ICCT2.2017.7972304.
- [4] C.-P. Ooi, W.-H. Tan, S.-N. Cheong, Y.-L. Lee, V. M. Baskaran, and Y.-L. Low, "FPGA-based embedded architecture for IoT home automation application," *Indonesian Journal of Electrical Engineering and Computer Science (IJECS)*, vol. 14, no. 2, pp. 646–652, May 2019, doi: 10.11591/ijeecs.v14.i2.pp646-652.
- [5] Y. D. Setiawan, B. Ghilchrist, G. Giovan, and M. H. Widiyanto, "Development of IoTs-based instrument monitoring application for smart farming using solar panels as energy source," *International Journal of Reconfigurable and Embedded Systems (IJRES)*, vol. 12, no. 2, pp. 248–259, Jul. 2023, doi: 10.11591/ijres.v12.i2.pp248-259.
- [6] E. M. M. Yusof, M. I. Yusof, R. Ali, I. H. Harjimi, and Q. K. Bahrin, "Welding station monitoring system using internet of thing (IoT)," *Indonesian Journal of Electrical Engineering and Computer Science (IJECS)*, vol. 18, no. 3, pp. 1319–1330, Jun. 2020, doi: 10.11591/ijeecs.v18.i3.pp1319-1330.
- [7] M. S. A. Mahmud, S. Buyamin, M. M. Mokji, and M. S. Z. Abidin, "Internet of Things based Smart Environmental Monitoring for Mushroom Cultivation," *Indonesian Journal of Electrical Engineering and Computer Science (IJECS)*, vol. 10, no. 3, pp. 847–852, Jun. 2018, doi: 10.11591/ijeecs.v10.i3.pp847-852.
- [8] M. S. Mispan, A. Z. Jidin, M. R. Kamaruddin, and H. M. Nasir, "Proof of concept for lightweight PUF-based authentication protocol using NodeMCU ESP8266," *Indonesian Journal of Electrical Engineering and Computer Science (IJECS)*, vol. 24, no. 3, pp. 1392–1398, Dec. 2021, doi: 10.11591/ijeecs.v24.i3.pp1392-1398.
- [9] T. Sutikno, H. S. Purnama, A. Pamungkas, A. Fadlil, I. M. Alsofyani, and M. H. Jopri, "Internet of things-based photovoltaics parameter monitoring system using NodeMCU ESP8266," *International Journal of Electrical and Computer Engineering (IJECE)*, vol. 11, no. 6, pp. 5578–5587, Dec. 2021, doi: 10.11591/ijece.v11i6.pp5578-5587.
- [10] O. I. Adebisi, I. A. Adejumbi, S. Matthew, and A. A. Abdulsalam, "Development of a web-based single-phase load monitoring and auditing system," *International Journal of Electrical and Computer Engineering (IJECE)*, vol. 12, no. 6, pp. 6785–6795, Dec. 2022, doi: 10.11591/ijece.v12i6.pp6785-6795.
- [11] H. Salameh, M. Dhainat, and E. Benkhelifa, "A Survey on Wireless Sensor Network-Based IoT Designs For Gas Leakage

- Detection and Fire-Fighting Applications,” *Jordanian Journal of Computers and Information Technology*, vol. 5, no. 2, pp. 60–72, 2019, doi: 10.5455/jjcit.71-1550235278.
- [12] M. Santiputri and M. Tio, “IoT-based gas leak detection device,” in *2018 International Conference on Applied Engineering (ICAE)*, Oct. 2018, pp. 1–4, doi: 10.1109/INCAE.2018.8579396.
- [13] J. B. A. Gomes, J. J. P. C. Rodrigues, R. A. L. Rabêlo, N. Kumar, and S. Kozlov, “IoT-enabled gas sensors: Technologies, applications, and opportunities,” *Journal of Sensor and Actuator Networks*, vol. 8, no. 4, p. 57, Dec. 2019, doi: 10.3390/jsan8040057.
- [14] Q. Xilong, L. Shengzong, F. Sha, H. Hong, H. Ying, and X. Leyi, “Design and implementation of wireless environment monitoring system based on STM32,” *Scientific Programming*, vol. 2021, pp. 1–15, Oct. 2021, doi: 10.1155/2021/6070664.
- [15] A. Skraba, A. Kolozvari, D. Kofjac, R. Stojanovic, V. Stanovov, and E. Semenkin, “Prototype of group heart rate monitoring with NODEMCU ESP8266,” in *2017 6th Mediterranean Conference on Embedded Computing (MECO)*, Jun. 2017, pp. 1–4, doi: 10.1109/MECO.2017.7977151.
- [16] X. Xie and W. Jiang, “Intelligent fishpond monitoring system based on STM32 and Zigbee,” *Research Journal of Applied Sciences, Engineering and Technology*, vol. 13, no. 6, pp. 495–502, Sep. 2016, doi: 10.19026/rjaset.13.3009.
- [17] Y. S. Parihar, “Internet of things and Nodemcu a review of use of Nodemcu ESP8266 in IoT products,” *Journal of Emerging Technologies and Innovative Research*, vol. 6, no. 6, pp. 1085–1088, 2019, doi: 10.13140/RG.2.2.34456.75525.
- [18] M. A. Omran, B. J. Hamza, and W. K. Saad, “The design and fulfillment of a Smart Home (SH) material powered by the IoT using the Blynk app,” *Materials Today: Proceedings*, vol. 60, pp. 1199–1212, 2022, doi: 10.1016/j.matpr.2021.08.038.
- [19] E. Sutanto, T. S. Putra, A. Kuncahyojati, and E. I. Agustin, “IoT based electricity leakage current monitoring using Blynk app,” in *AIP Conference Proceedings*, 2020, vol. 2314, no. 1, p. 040004, doi: 10.1063/5.0034352.
- [20] N. A. Z. M. Noar and M. M. Kamal, “The development of smart flood monitoring system using ultrasonic sensor with blynk applications,” in *2017 IEEE 4th International Conference on Smart Instrumentation, Measurement and Application (ICSIMA)*, Nov. 2017, pp. 1–6, doi: 10.1109/ICSIMA.2017.8312009.
- [21] H. Durani, M. Sheth, M. Vaghasia, and S. Kotech, “Smart automated home application using IoT with Blynk app,” in *2018 Second International Conference on Inventive Communication and Computational Technologies (ICICCT)*, Apr. 2018, pp. 393–397, doi: 10.1109/ICICCT.2018.8473224.
- [22] A. Hadi, Z. Abidin, and T. Dewantoro, “Study of characteristic MPX5700AP sensor for pressure system monitoring based various units,” in *Proceeding International Applied Business and Engineering Conference*, 2022, pp. 129–133.
- [23] J. Gupta, A. Patil, S. Rajgire, and T. Kadus, “Smart LPG monitoring and automatic booking system using IOT,” *International Journal of Engineering Research & Technology (IJERT)*, vol. 9, no. 4, pp. 404–407, 2020.
- [24] D. Hasan and A. Ismaeel, “Designing ECG Monitoring Healthcare System Based on Internet of Things Blynk Application,” *Journal of Applied Science and Technology Trends*, vol. 1, no. 3, pp. 106–111, Jul. 2020, doi: 10.38094/jastt1336.
- [25] T. Zhang, J. Shi, X. Qian, and Y. Ai, “Temperature and gas pressure monitoring and leachate pumping tests in a newly filled MSW layer of a landfill,” *International Journal of Environmental Research*, vol. 13, no. 1, pp. 1–19, Feb. 2019, doi: 10.1007/s41742-018-0157-0.
- [26] P. Karrupusamy, “A sensor based IoT monitoring system for electrical devices using Blynk framework,” *Journal of Electronics and Informatics*, vol. 2, no. 3, pp. 182–187, Aug. 2020, doi: 10.36548/jei.2020.3.005.
- [27] S. A. Z. Murad, F. A. Bakar, A. Azizan, and M. A. M. Shukri, “Design of internet of things based air pollution monitoring system using ThingSpeak and Blynk application,” *Journal of Physics: Conference Series*, vol. 1962, no. 1, p. 012062, Jul. 2021, doi: 10.1088/1742-6596/1962/1/012062.
- [28] A. Ahsan, M. Z. Lslam, R. Siddiqua, and M. K. Rhaman, “An IoT based interactive LPG cylinder monitoring system with sensor node based safety protocol for developing countries,” in *2020 IEEE Region 10 Symposium (TENSYP)*, 2020, pp. 398–401, doi: 10.1109/TENSYP50017.2020.9230875.
- [29] M. A. Hannan *et al.*, “Development of LPG leakage detector system using arduino with Internet of Things (IoT),” *Journal of Telecommunication, Electronic and Computer Engineering (JTEC)*, vol. 10, no. 2–7, pp. 91–95, 2018.
- [30] R. K. Kodali, D. B. Tirumala, and S. C. Rajanarayanan, “IOT based automatic LPG gas booking and leakage detection system,” in *2019 11th International Conference on Advanced Computing (ICoAC)*, Dec. 2019, pp. 338–341, doi: 10.1109/ICoAC48765.2019.246863.
- [31] A. K. Srivastava, S. Thakur, A. Kumar, and A. Raj, “IoT based LPG cylinder monitoring system,” in *2019 IEEE International Symposium on Smart Electronic Systems (iSES) (Formerly iNiS)*, Dec. 2019, pp. 268–271, doi: 10.1109/iSES47678.2019.00066.
- [32] Z. L. Oo, T. W. Lai, and A. Moe, “IoT based LPG gas level detection & gas leakage accident prevention with alert system,” *Balkan Journal of Electrical and Computer Engineering*, vol. 9, no. 4, pp. 404–409, Oct. 2021, doi: 10.17694/bajece.946789.
- [33] P. Veerakumar, “Energy monitoring system to display on web page using ESP8266,” *Indonesian Journal of Electrical Engineering and Computer Science (IJECS)*, vol. 9, no. 2, pp. 286–288, Feb. 2018, doi: 10.11591/ijeecs.v9.i2.pp286-288.
- [34] M. S. Mispan, A. Z. Jidin, H. M. Nasir, N. M. A. Brahin, and I. M. Nawil, “Modeling arbiter-PUF in NodeMCU ESP8266 using artificial neural network,” *International Journal of Reconfigurable and Embedded Systems (IJRES)*, vol. 11, no. 3, pp. 233–239, Nov. 2022, doi: 10.11591/ijres.v11.i3.pp233-239.
- [35] A. M. A. Jalil, R. Mohamad, N. M. Anas, M. Kassim, and S. I. Suliman, “Implementation of vehicle ventilation system using NodeMCU ESP8266 for remote monitoring,” *Bulletin of Electrical Engineering and Informatics*, vol. 10, no. 1, pp. 327–336, Feb. 2021, doi: 10.11591/eei.v10i1.2669.
- [36] R. S. Rosli, M. H. Habaebi, and M. R. Islam, “On the analysis of received signal strength indicator from ESP8266,” *Bulletin of Electrical Engineering and Informatics*, vol. 8, no. 3, pp. 933–940, Sep. 2019, doi: 10.11591/eei.v8i3.1511.
- [37] H. R. Fajrin, S. K. Afifah, and S. A. Wibowo, “Mixed pressure control innovation of oxygen and air pressure in ventilator with safety valve,” *Journal of Physics: Conference Series*, vol. 1933, no. 1, p. 012106, Jun. 2021, doi: 10.1088/1742-6596/1933/1/012106.



**BIOGRAPHIES OF AUTHORS**

**Tole Sutikno**    is a lecturer in the Master Program of Electrical Engineering, Faculty of Industrial Technology, Universitas Ahmad Dahlan, Indonesia. He received his B.Eng., M.Eng., and Ph.D. degrees in Electrical Engineering from Universitas Diponegoro, Universitas Gadjah Mada, and Universiti Teknologi Malaysia, in 1999, 2004, and 2016, respectively. He has been an Associate Professor at UAD, Yogyakarta, Indonesia since 2008. He is currently an Editor-in-Chief of the TELKOMNIKA and the Head of the Embedded Systems and Power Electronics Research Group (ESPERG). His research interests include the fields of digital design, industrial applications, industrial electronics, industrial informatics, power electronics, motor drives, renewable energy, FPGA applications, embedded systems, artificial intelligence, intelligent control, information technology, and digital libraries. He can be contacted at email: [tole@te.uad.ac.id](mailto:tole@te.uad.ac.id).





**Muhamad Haikal Ar-Rasyid**    received a B. Eng. in electrical engineering from Universitas Ahmad Dahlan, Indonesia, in 2023. His research interests include renewable energy technology, robotics, and the internet of things. He can be contacted at email: [muhamad1700022073@webmail.uad.ac.id](mailto:muhamad1700022073@webmail.uad.ac.id).



**Tri Wahono**    is currently a researcher at the Embedded System and Power Electronics Research Group (ESPERG), Indonesia. He received a bachelor's degree in Electrical Engineering from Universitas Ahmad Dahlan, Yogyakarta, Indonesia, in 2017, and he is currently master's degree from the Master Program of Electrical Engineering, Faculty of Industrial Technology, Universitas Ahmad Dahlan, Indonesia. His research interests include power electronics, renewable energy technology, robotics, and the internet of things. He can be contacted at email: [triwahono060@gmail.com](mailto:triwahono060@gmail.com).



**Watra Arsadiando**    received a B. Eng. in electrical engineering from Universitas Ahmad Dahlan, Indonesia, in 2017. He is a member of the Embedded Systems & Power Electronics Research Group (ESPERG). His current research interests include renewable energy, robotics, and digital control systems. He can be contacted at email: [watra24arsadiando@gmail.com](mailto:watra24arsadiando@gmail.com) or [watra@journal.uad.ac.id](mailto:watra@journal.uad.ac.id).