

PAPER

Archimedes' principle experimental apparatus for remote physics laboratory

To cite this article: T K Indratno *et al* 2024 *Phys. Educ.* **59** 025029

View the [article online](#) for updates and enhancements.

You may also like

- [Construction and remote demonstration of an inexpensive but efficient experimental setup for studying self-inductance and mutual-inductance between two coils](#)
Arijit Roy, Munmun Ghosal, Abhishek Mallick et al.
- [Novel demonstration of the Doppler shift of planet spectra](#)
Matthew Lewis
- [Investigating the effect of coolant on cooling rate of engine oil used in automobile industry using Arduino interfaced temperature sensor](#)
Amit Kumar Pandey, Raghav Sharma, Nikhil et al.

Archimedes' principle experimental apparatus for remote physics laboratory

T K Indratno* , Ishafit and Y D Prabowo

Physics Education Department, Universitas Ahmad Dahlan, Yogyakarta, Indonesia

E-mail: tonikus@staff.uad.ac.id



CrossMark

Abstract

The latest developments in information technology have made it possible to have experimental activities that can be accessed remotely. This article offers an explanation about the development of experimental tools that can be accessed remotely based on Archimedes' principle. The equipment has been developed by adding a stepper motor to control the object to submerge in liquid. The stepper motor is controlled by Arduino Uno using the graphical user interface (GUI) developed using LabVIEW. Data sampling process uses a force sensor that is controlled using the same GUI. Based on the equipment that has been developed, experiments on the principle of Archimedes' can be done online through websites. The experimental results agree with theoretical calculations and with previous research. Therefore, the developed apparatus can be used as an experimental-based learning tool in an online platform.

Keywords: remote experiment, Archimedes' principle, remote laboratory

1. Introduction

Archimedes' principle is one of the fundamental topics of fluid mechanics in school [1]. A strong comprehension of Archimedes' principles can significantly enhance a student's grasp of various fluid mechanical concepts [2]. This principle states that if an object is immersed in a liquid, either wholly or partially, it is buoyed up equal to the weight of the liquid transferred by the object. Using Archimedes' principle, fluid density can be

calculated [3] through several investigations. The density of an object can also be determined from the known density of the liquid. Due to lack of physical resources in certain schools, lessons pertaining to the aforementioned principle are often confined to theoretical discussions, devoid of any practical hands-on experience [4].

Based on previous studies, experiments on Archimedes' principle can be done using spring balance [5] or triple beam balance. The load is hung on the balance, then immersed in liquid. The buoyant force value is then obtained, which equals the weight of the liquid being moved. Gianino [6]

* Author to whom any correspondence should be addressed.

developed an experimental method to determine fluid density using a microcomputer-based laboratory (MBL), which consists of a force sensor, computer, and data acquisition system for better results. In this case, the load is hung on the force sensor. Then the object is slowly dipped into the liquid. The MBL system will display the relationship graph between the object's submerged volume vs. the buoyant force experienced by the object.

A similar apparatus was also developed by Ozvoldová *et al* [7], who developed an experimental apparatus based on Archimedes' principle for remote experiments. They reported that the object was hung on a dynamometer connected to a computer. The container with liquid was lifted by the setup operated remotely until the hanging object was immersed. Data on the object's immersed depth and buoyancy force is recorded through a data acquisition system developed using Java Applet. This system can also be accessed online through certain applications on websites.

Previous studies have shown that a software control to submerge the object in the liquid is not yet available. This software control allows full control of the data acquisition process to support remote experimentation. In research [7], software control was carried out in a container with liquid. Shocks may occur in the liquid, interfering in the data obtained. Therefore, the development of an experimental apparatus based on Archimedes' principle is needed. This article discusses the development of experimental apparatus for remote laboratory based on Archimedes' principle. The novelty of the device being developed lies in the device control and the data acquisition system. Users can perform device control and data acquisition through a graphical user interface (GUI) created using LabVIEW. This experimental tool, which uses Archimedes' principle and is based on this remote laboratory, can be used for learning physics.

2. Materials and methods

The experimental apparatus based on Archimedes' principle was developed in three steps: studying Archimedes' principle in physics,

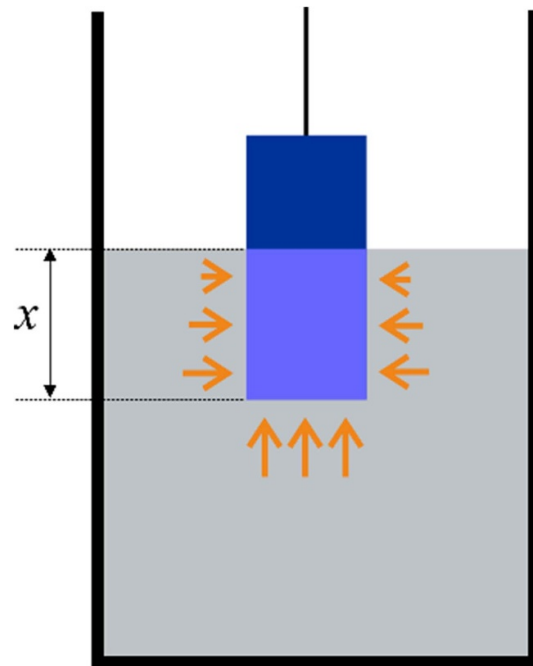

Figure 1. Forces due to pressure acting on the surface of a partially immersed body. Reprinted from [6], with the permission of AIP Publishing.

designing hardware, and creating software for control systems and data acquisition.

2.1. Archimedes' principle

When an object is immersed in a liquid, it experiences a buoyant force, F . This buoyant force is the net upward force on the object by the liquid [8]. The deeper the object sinks, the greater the buoyant force experienced by the object. Figure 1 (adapted from [9]) shows forces due to pressure acting on the surface of a partially immersed body.

Archimedes' principle is mathematically written as,

$$F_{\text{up}} = \rho g V_x \quad (1)$$

where ρ is the density of the liquid, g is the acceleration due to gravity, and V_x is the volume of the fraction of the submerged object.

When an object is hung on a force sensor, and the object is in a state of static equilibrium, the

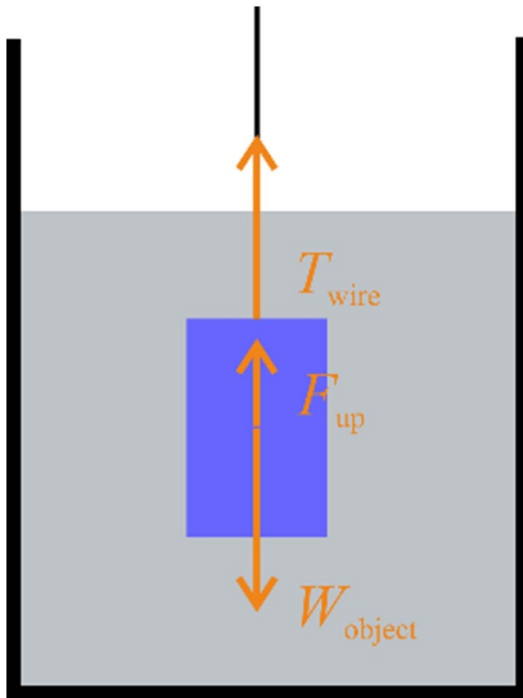

Figure 2. A forces acting on a submerged object. Reprinted from [6], with the permission of AIP Publishing.

sensor directly reads the tension on the string as shown in equation (2),

$$W_{\text{app}} = m_{\text{app}}g = T_{\text{wire}} \quad (2)$$

where m_{app} is the object's mass, while W_{app} is the weight of an object when it is suspended in the air. If the suspended object is immersed in a liquid, the tension in the rope will be less than the object's weight because of the buoyant force. The formula of the forces acting on objects is shown in figure 2 (adapted from [9]). The net force on the object can be expressed by equation (3),

$$\sum F_y = T_{\text{wire}} + F_{\text{up}} - W_{\text{object}} \quad (3)$$

where W_{object} is the weight of the object that is read on the sensor when the volume of the object is submerged. Using equations (2) and (3), the value of the buoyant force acting on the object is,

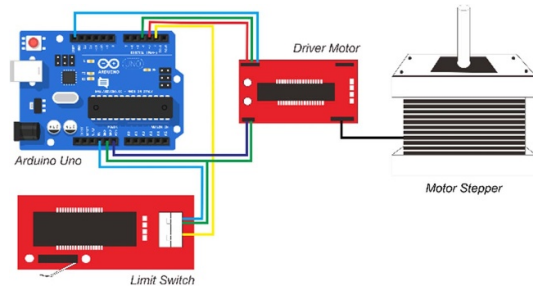

Figure 3. Schematic diagram of stepper motor control circuit.

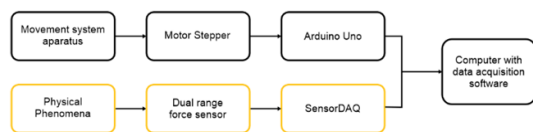

Figure 4. Hardware schematic design.

$$F_{\text{up}} = W_{\text{app}} - W_{\text{object}}. \quad (4)$$

2.2. Hardware design

The main component in developing this apparatus is (1) Arduino Uno as a microcontroller for communication between hardware and software, as well as a device controller, (2) Nema 17HS4401 stepper motor to move the object. The stepper motor is connected vertically using a lead screw, which is a rail where the object moves up and down. The stepper motor is controlled by the Arduino Uno using a circuit (figure 3) to adjust the object's moves, so it can be immersed in liquid. The limit switch is used as an upper limit for object movements.

Experimental data on the weight of an object suspended in the air or submerged in liquid is obtained using a Force Sensor from Vernier Technology. This apparatus can read forces from 0.01 to 50 newtons [10]. The Force Sensor is connected to the computer via SensorDAQ, a data acquisition interface from National Instrument (NI) and Vernier. SensorDAQ has three analogs and one digital channel with a maximum capacity of up to 48 000 samples per second [11]. The hardware schematic diagram of the experiment is displayed in figure 4.

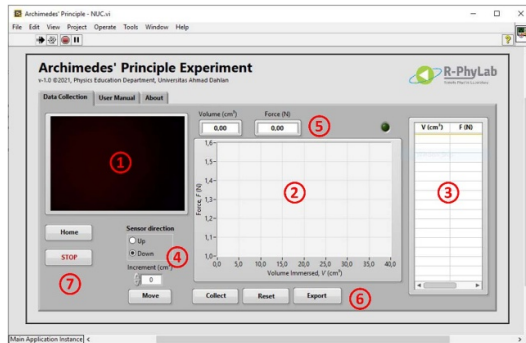

Figure 5. The experimental software's GUI based on Archimedes' principle.

2.3. Control system development

The control system is made with a GUI, which is simple and easy to use. The GUI is developed using LabVIEW software. LabVIEW, originally from NI, is a block diagram-based programming language for creating virtual instrumentation. LabVIEW software has three main parts: a front panel for creating GUIs, a block diagram as programming code, and a connector panel for connection between components made [12]. LabVIEW is used for GUI development because it features web publishing tools, so the developed GUI can be accessed remotely via the website.

The experimental software's GUI design based on Archimedes' principle is shown in figure 5. The two main parts of this experimental software are device settings and data acquisition systems. The tool setting instructs the stepper motor to move downwards to submerge the object in the liquid. The data acquisition system displays the object buoyancy data that is read by the sensor. The data is in tables and graphs. Block diagrams for device settings and stepper motor control can be seen in appendix A, while the block diagrams for data acquisition systems and camera displays can be seen in appendices B and C.

There are seven main elements in the experimental software's GUI based on Archimedes' principle with different functions: (1) an apparatus monitor to display experimental apparatus, (2) a graphic panel to display data in graphic form, (3) a table panel, which displays data in tabular form, (4) switch to adjust the direction of

motion of the sensor, (5) current monitor, which displays real-time data, (6) buttons to retrieve data of object volume and buoyant force experienced by the object, and (7) buttons to start and end the experiment.

This experimental system can be used offline or online. In offline use, the user installs it, then connects the experimental apparatus to a computer via a USB connection. Meanwhile, this system must first be published into HTML code via the web publishing tools available in LabVIEW for remote experimental online use. After publishing, users can access the system and its apparatus via the website. The architecture of remote laboratory system (see figure 6) used in this experiment is as described in [13]. The experimental apparatus is connected to a computer on a lab server. Through the lab server computer, the data acquisition system is published as HTML to be accessed by users via the internet.

3. Results and discussion

3.1. Result

Figure 7 displays the apparatus used in the Archimedes' principle experiment, including all associated hardware. The novelty of this study, when compared to the research [6], lies in the computerization of hardware control systems. The stepper motor is computerized and controlled to immerse the object into the liquid. Meanwhile, compared to research [7], the difference is in the type of sensor used and the data collection process. The Dual-Range Force Sensor from Vernier Technology was used in this study, and the event collected data by entering.

The apparatus developed can be used for learning physics with remote laboratory-based experiment methods. Using the camera installed in the system, students can observe the experimental apparatus, control the apparatus, and control the data collection process. This apparatus can be accessed remotely using a GUI embedded in the remote laboratory web portal, <http://rphyllab.pf.uad.ac.id/sistem/>. Users can create an account independently and confirm experimental activities to the administrator via e-mail to rphyllab@pfis.uad.ac.id. Figure 8 shows the

Archimedes' principle experimental apparatus for remote physics laboratory

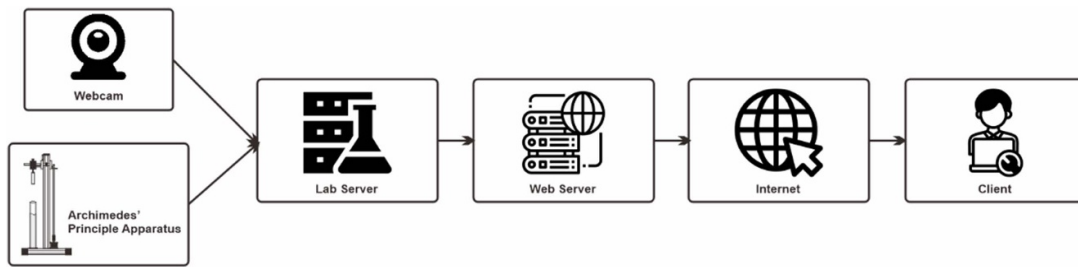

Figure 6. The architecture of remote laboratory system. Reproduced from [13]. © IOP Publishing Ltd. All rights reserved.



Figure 7. Image of the experimental apparatus based on Archimedes' principle for remote laboratory.

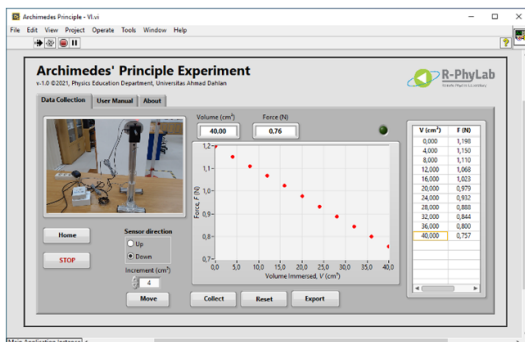

Figure 8. Archimedes' principle experiment with an online remote laboratory.

results of Archimedes' principle experiment and access to the apparatus remotely via the website.

In this study, the experimental apparatus involving Archimedes' principle was used to verify the density of liquids. In this case, water and alcohol were used. Blocks of dimensions $2.5 \times 1 \times 18$ cm were immersed from 4 cm^3 to

Table 1. Experimental result.

Volume ($\times 10^{-5} \text{ m}^3$)	Buoyant force (N)	
	Water	Ethanol
4	0.033	0.038
8	0.079	0.076
12	0.122	0.114
16	0.165	0.153
20	0.209	0.192
24	0.250	0.230
28	0.292	0.267
32	0.336	0.306
36	0.378	0.344
40	0.420	0.384

40 cm^3 . Users can observe the movement of the objects when immersed through video streaming from the camera installed in the apparatus.

3.2. Discussion

As shown in figure 8, V_x and the sensor reading, show a linear relationship. The force read on this sensor is the object's gravitational force. The buoyant force experienced by an object can be determined using equation (3). Table 1 shows the relationship between the volume of a sinking object and the buoyant force experienced by the object based on the experimental results.

Figure 9 shows the results of fitting the data into a linear equation, with the volume of the immersed object (V_x) as the dependent variable x and the upward pressure force as the independent variable y .

Using equation (1) and comparing it with the equation of a straight line, $y = mx$, the slope of a line is $m = \rho g$. Using this slope, one can find

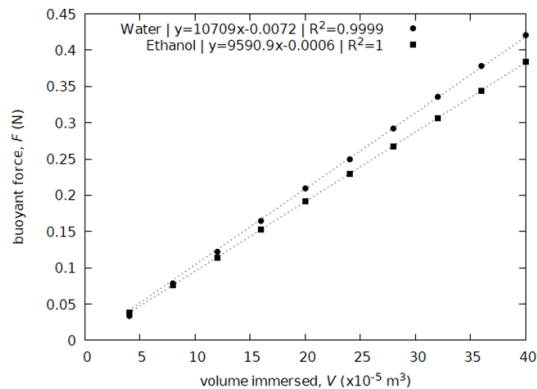

Figure 9. The graph of the relationship between the volume of objects immersed with buoyant force on objects.

Table 2. Results of the calculation of the value of the density of liquids.

Liquid	Slope	R^2	ρ (Kg m^{-3})	% Error
Water	10 709	0.9999	1092.76	0.09
Ethanol	9590.9	1.0000	980.66	0.18

the density of the unknown liquid ($g = 9.8 \text{ m s}^{-2}$ [4]). The results of the calculation of the density of water and ethanol are shown in table 2.

The relative error is obtained by comparing the experimental results with [3]. The experimental results in this study confirm the results of similar previous studies [3, 5, 6]. Therefore, the apparatus that has been developed can verify the fluid density value with good results.

The experimental apparatus (and also for GUI) developed needs to be equipped with a liquid temperature sensor, as liquid temperature measurements are still performed manually by an operator who will convey the results to the user through the remote laboratory portal. In addition, users cannot replace automatic liquids during experiments online. Fluid replacement is carried out by an operator based on user's requests. However, the accuracy and precision resulting

from the apparatus are close to the value theoretically expected, so it can be used for learning physics with the online experimental method.

After experimenting in R-PhyLab, users fill out a questionnaire created based on the USE Questionnaire [14], which examines several dimensions of usability, including usefulness, ease of use, easy of learning, and satisfaction. Usefulness refers to the benefits of R-PhyLab for users. Easy of use examines how easy it is to use R-PhyLab. Ease of learning shows how easy it is to learn to operate R-PhyLab, while satisfaction examines user's satisfaction after using R-PhyLab.

The results of the questionnaire survey show that R-PhyLab gets a positive response from users. According to the users, some aspects of R-PhyLab operation that cannot be done at any time must be considered. This is because the use R-PhyLab typically depends on the role of an operator. In addition, the use of R-PhyLab requires a fast and stable internet connection, and this may not be possible for some users who have unstable or inconsistent internet access due to geographical location [15].

Future research, could develop an R-PhyLab system that minimizes the operator's role so that R-PhyLab can be accessed anytime.

4. Conclusion

An experimental apparatus for remote physics laboratories based on Archimedes' principle has been successfully developed. This apparatus and its data acquisition system have demonstrated a linear relationship between the volume of an immersed object and the buoyant force that the object experiences. Thus, the apparatus is feasible to be used for experiments to verify the density value of a liquid through the application of Archimedes' principle.

Data availability statement

No new data were created or analysed in this study.

Appendix A. Block diagram for device setup and stepper motor control

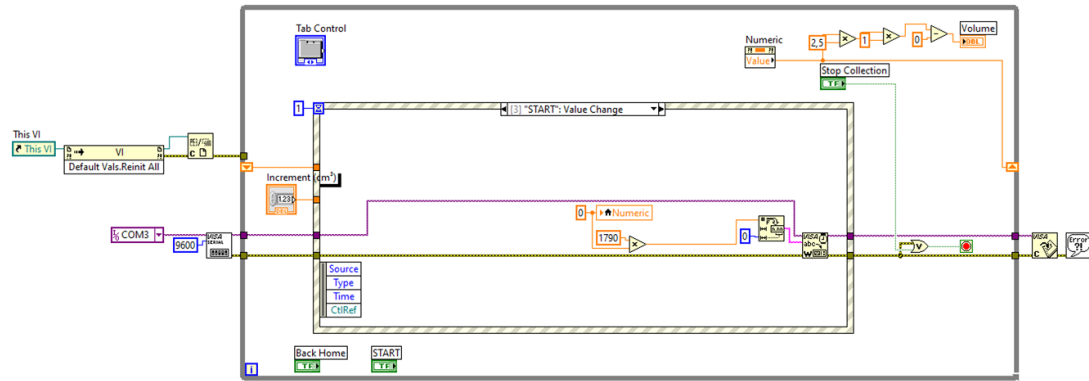

Appendix B. Data acquisition system block diagram

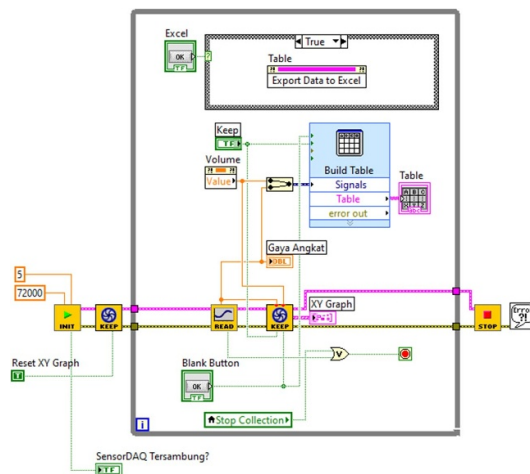

Appendix C. Camera panel block diagram

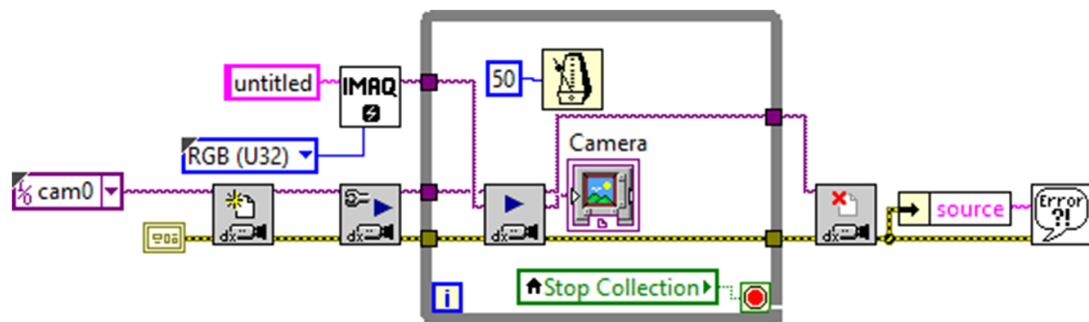

ORCID iD

T K Indratno  <https://orcid.org/0000-0001-8852-6231>

Received 29 November 2022, in final form 19 October 2023
 Accepted for publication 8 February 2024
<https://doi.org/10.1088/1361-6552/ad27a6>

References

[1] Mohazzab P 2017 Archimedes' principle revisited *J. Appl. Math. Phys.* **5** 836–43

[2] Kusairi S, Rosyidah N D, Diyana T N and Nisa I K 2020 Conceptual understanding and difficulties of high school students in urban and rural areas: case of Archimedes' principles *AIP Conf. Proc.* **2215** 050010

[3] Hughes S W 2006 Measuring liquid density using Archimedes' principle *Phys. Educ.* **41** 445–7

[4] Wilcox B R and Lewandowski H J 2017 Developing skills versus reinforcing concepts in physics labs: insight from a survey of students' beliefs about experimental physics *Phys. Rev. Phys. Educ. Res.* **13** 010108

[5] Struganova I 2005 A spring, Hooke's law, and Archimedes' principle *Phys. Teach.* **43** 516–8

[6] Gianino C 2008 Microcomputer-based laboratory for Archimedes' principle and density of liquids *Phys. Teach.* **46** 52–54

[7] Ožvoldová M, Špiláková P and Tkáč L 2014 Archimedes' principle-internet accessible remote experiment *Int. J. Interact. Mob. Technol.* **10** 36–42

[8] Cavazzini G 2019 Archimedes' principle and the concept of gravitation *Appl. Phys. Res.* **11** 9

[9] Department of Physics 2019 *Archimedes' Principle Lab Manual* (Brooklyn) (available at: <http://depthome.brooklyn.cuny.edu/physics/lab/phy1/Archimedes-principle-rev-20190619.pdf>)

[10] Technology V 2019 *Dual-Range Force Sensor User Manual* (available at: www.vernier.com/manuals/dfs-bta/)

[11] Ishaftit I, Indratno T K and Prabowo Y D 2020 Arduino and LabVIEW-based remote data acquisition system for magnetic field of coils experiments *Phys. Educ.* **55** ab5ed6

[12] Wrobel P M, Bogovac M, Sghaier H, Leani J J, Migliori A, Padilla-Alvarez R, Czyzycki M, Osan J, Kaiser R B and Karydas A G 2016 LabVIEW interface with Tango control

system for a multi-technique x-ray spectrometry IAEA beamline end-station at Elettra Sincrotrone Trieste *Nucl. Instrum. Methods Phys. Res. A* **833** 105–9

[13] Ishaftit M and Surjono H D 2021 Development of light polarization experimental apparatus for remote laboratory in physics education *Phys. Educ.* **56** abc4da

[14] Lund A M 2001 Measuring usability with the USE questionnaire *Usability Interface* **8** 3–6 (available at: www.stcsig.org/usability/newsletter/index.html)

[15] Ramdhan M, Sukarelawan M I, Thohir M A and Arifiyanti F 2022 Junior high school student perception of online learning in pandemic Covid-19: gender, social media ownership, and internet access duration perspective *Int. J. Educ. Learn.* **4** 28–40



Toni Kus Indratno is a lecturer in the physics education department at Universitas Ahmad Dahlan. His current research interest focuses on the application of ICTs (smartphones/computers) in learning physics. Besides, he and his team are developing a remote-based laboratory (R-Phylab) for distance physics learning.



Ishaftit is an Associate Professor in the Department of Physics Education at Universitas Ahmad Dahlan. He received his doctoral degree at Universitas Negeri Yogyakarta in 2021 and has taught physics for over 25 years. His current research interests are laboratory-based physics instruction and ICT-based physics experiments.



Yoga Dwi Prabowo is a laboratory assistant at the Ahmad Dahlan University Science Learning Technology Laboratory (LTPS). Currently he is actively part of the team that developed the Remote Physics Laboratory (R-Phylab).