

### Submission Information

Author Name	Riky Dwi Puriyanto
Title	Temperature and Lighting Control of Deep Water Culture Hydroponic System in Automatic Miniroom Space
Paper/Submission ID	1578666
Submitted by	zulfa.erlin@staff.uad.ac.id
Submission Date	2024-03-28 11:14:57
Total Pages	10
Document type	Article

### Result Information

Similarity **14 %**

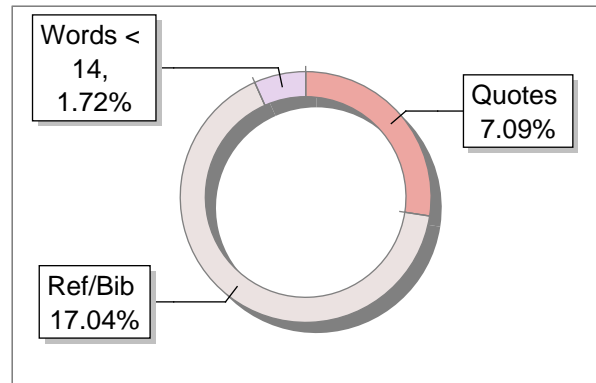
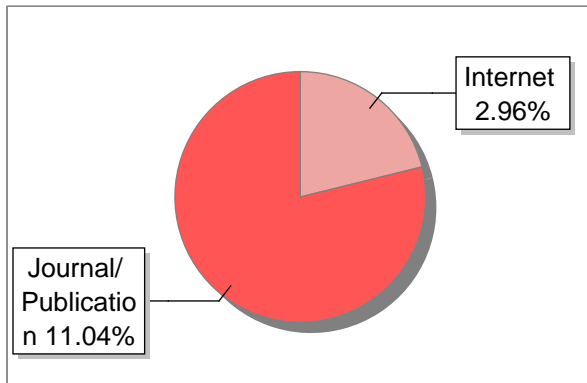
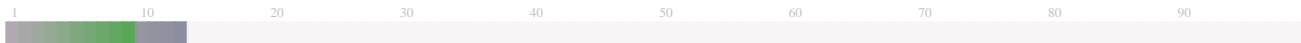

### Exclude Information

Quotes	Excluded
References/Bibliography	Excluded
Sources: Less than 14 Words %	Not Excluded
Excluded Source	<b>8 %</b>
Excluded Phrases	Not Excluded

### Database Selection

Language	English
Student Papers	Yes
Journals & publishers	Yes
Internet or Web	Yes
Institution Repository	Yes

A Unique QR Code use to View/Download/Share Pdf File



**DrillBit Similarity Report**

# 14

SIMILARITY %

# 20

MATCHED SOURCES

# B

GRADE

**A-Satisfactory (0-10%)**
**B-Upgrade (11-40%)**
**C-Poor (41-60%)**
**D-Unacceptable (61-100%)**

LOCATION	MATCHED DOMAIN	%	SOURCE TYPE
2	journal2.uad.ac.id	3	Publication
3	IEEE 2018 4th International Conference on Electrical, Electronics a, by Binti Mohd Arifin, - 2018	2	Publication
4	beautymama.com.hk	1	Internet Data
5	Design and Development of Disabled Parking System for Smart City by Gining-2018	1	Publication
6	smujo.id	1	Publication
7	www.dx.doi.org	<1	Publication
9	IEEE TENCON 2017- 2017 IEEE Region 10 Conference- Penang (2017.11, by Fermin, Christian K- 2017	1	Publication
10	cctv.bleekofsweden.com	1	Internet Data
11	repository.futminna.edu.ng 8080	1	Publication
12	journal2.uad.ac.id	<1	Publication
17	sportdocbox.com	<1	Internet Data
18	Adaptive active contour model driven by fractional order fitting energy by Ren-2015	<1	Publication

19	<a href="http://eprints.umm.ac.id">eprints.umm.ac.id</a>	<1	Internet Data
20	<a href="http://scientific.net">scientific.net</a>	<1	Internet Data
21	<a href="http://journal.umy.ac.id">journal.umy.ac.id</a>	<1	Internet Data
22	Recognising the kind of cloud using a new fuzzy knowledge-based system by Neshat-2016	<1	Publication
24	<a href="http://www.ncbi.nlm.nih.gov">www.ncbi.nlm.nih.gov</a>	<1	Internet Data
25	<a href="http://www.journal.uad.ac.id">www.journal.uad.ac.id</a>	1	Publication
32	<a href="http://www.adb.org">www.adb.org</a>	1	Publication
40	<a href="http://simple.ascee.org">simple.ascee.org</a>	<1	Internet Data

**EXCLUDED SOURCES**

1	<a href="http://journal2.uad.ac.id">journal2.uad.ac.id</a>	8	Publication
---	--	---	-------------

## Temperature and Lighting Control of **4** Deep Water Culture Hydroponic System in Automatic Miniroom Space

**40** Kurniawan Dwi Yulianto, Riky Dwi Puriyanto  
Department of Electrical Engineering, Universitas Ahmad Dahlan, Yogyakarta, Indonesia

### ARTICLE INFORMATION

#### Article History:

Submitted 01 November 2022  
Revised 07 December 2022  
Accepted 13 January 2023

#### Keywords:

Hydroponic;  
Indoor;  
Temperature;  
Lighting;  
LED

#### Corresponding Author:

Riky Dwi Puriyanto,  
Department of Electrical  
Engineering,  
Universitas Ahmad Dahlan,  
Yogyakarta, Indonesia.  
Email: rikydp@ee.uad.ac.id

This work is licensed under a [Creative Commons Attribution-Share Alike 4.0](https://creativecommons.org/licenses/by-sa/4.0/)



### ABSTRACT

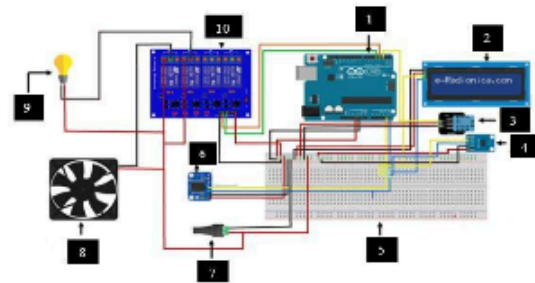

This research will develop a temperature control system and lighting using LEDs on automatic indoor hydroponic plants. The process of monitoring air temperature, light intensity and time in real time in a miniroom using a DHT-11 sensor, BH-1750 sensor, RTC, and Arduino Uno for data processing. **21** The results of this study indicate that the prototype made can work well. The DHT-11, BH-1750 and RTC sensors used in this study can work optimally. Temperature measurement using the DHT-11 Sensor has an Error value of 1.44% and Light Intensity Measurement using the BH-1750 Sensor has an Error value of 2.48% so that it can be used and applied to the system. This research works as expected where the system created can control the indoor temperature and lighting duration in the indoor hydroponic system.

#### Document Citation:

K. D. Yulianto and R. D. Puriyanto, "Temperature and Lighting Control of Deep Water Culture Hydroponic System in Automatic Miniroom Space," *Buletin Ilmiah Sarjana Teknik Elektro*, vol. 5, no. 1, pp. 12-21, 2023, DOI: 10.12928/biste.v5i1.6767.

## 1. INTRODUCTION

Hydroponics comes from the word hydro which means water and ponus which means power. Hydroponics can be interpreted as empowering water, namely the function of water as the core for growing plants and functioning in the process of plant physiology [1]. In the past, the hydroponic system was known as a planing method with media other than soil, and could be applied to a narrow area [2]. The hydroponic system itself has many methods that can be used for planting. One of them is growing using a hydroponic system with the Deep Water Culture (floating raft) method [3][9].

Deep water culture (DWC) is a technique in hydroponic systems that is desired to handle the process of providing nutrients to plants from the roots to the leaves [10], and handle the invasion of pests on the planting crown [4]. DWC uses the principle of submerging, draining, floating the planting or growing media for a certain duration of time [5]. In the submerging process, nutrients are provided from the roots to the crown and the crown is cleaned of pests [6]. In the draining process [7], oxygen is provided from the air to the roots to the crown and removes pests [8]. Furthermore, in the floating process, nutrients are provided only to the roots and oxygen is provided to the crown [11][12].

Growing with hydroponics has now become a breakthrough for city people [13]. However, sometimes the land owned is not necessarily enough to plant, so the solution can use an alternative way by planting indoors for additional land [14]. Planting with indoor hydroponics has special treatment so that plants can grow optimally [15]. However, people who just like plants sometimes forget to keep an eye on their plants because they are busy with their work schedule.

The background of the problem in this study is the lack of supervision of hydroponic plants that can affect the quality of plants [16], including the level of temperature and sunlight photosynthesis replacement lamps that affect the quality of plant growth [17]. Because these factors are certainly very concerned, if the temperature and humidity conditions are less stable, it will cause plants to wilt and the growth of disease seeds [18], which will cause the growth of lettuce plants to be less than optimal. Lettuce will grow ideally at a temperature of 20-30 [19]. Light is an important factor in the growth of lettuce, namely if irradiation lasts for 8-12 hours/day lettuce growth will be optimal because the absorption of nutrients will take place properly [20]. The lack of light can cause yellowing symptoms, where the stems become smaller and weaker, and the leaves are small, thin, and pale (not green). Symptoms of yellowing due to lack of light or plants in dark locations.

Based on the previous background, this research will develop a temperature and lighting control system for indoor hydroponic systems automatically, including room temperature and LED lighting. Since these parameters need to be considered regularly for the anticipated development of indoor hydroponic plant cultivation to develop ideally and have high quality.

## 2. METHODS

### 2.1. System Design

The system design in this research is divided into four parts. The first part is the design of the circuit schematic for the system, the goal is to know the components that will be used and make pengkbelan between each component. The second part is the design of the system flow chart, the goal is to know how the system works. The third part is designing the system block diagram, the goal is to know the component parts for input, processing and output on the system. The fourth part is the assembly of the DWC hydroponic system as a whole.

#### 2.1.1. System Circuit Schematic

The schematic design of the system circuit is the process of connecting all existing devices, so that later the system can read the value of the sensors used. The components used are Arduino uno, 20x4 LCD, DHT-11 sensor, BH-1750 sensor, Relay, 12V DC fan and 12V adapter. The red cable is the positive cable. The black cable is the negative cable. Wires with blue, yellow and green colors are the output or data cables. The system circuit schematic is shown in Figure 1 and the component descriptions are shown in Table 1. Information about the input and output data connected to the Arduino uno pins is shown in Table 2.

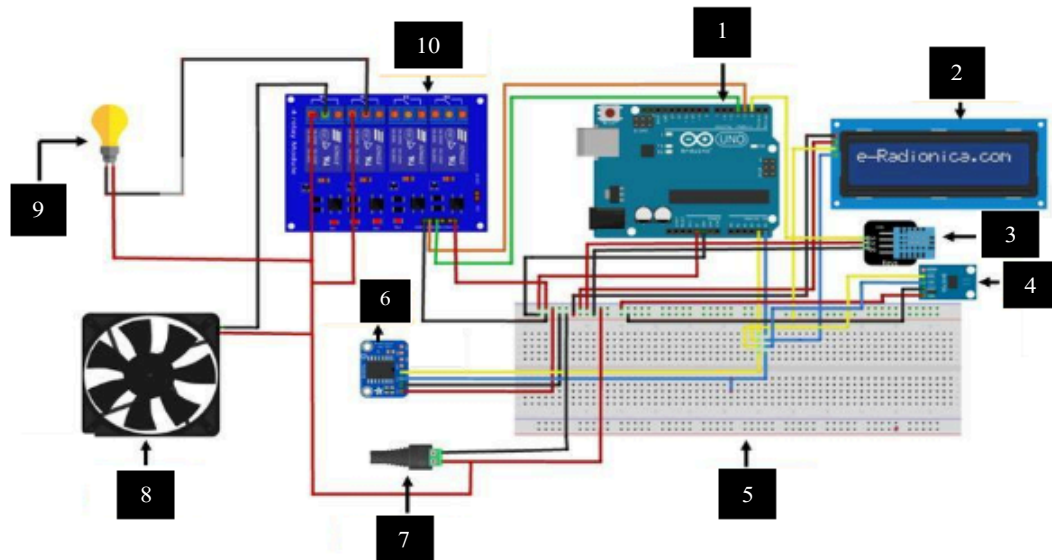

Figure 1. Schematic design of the system circuit

Table 1. Components with their functions

No	Name	Uses
1	Arduino UNO	As a microcontroller for controlling electronic components with the program
2	20x4 LCD	Used to provide information in the form of data on water level distance values and TDS values
3	Sensor DHT-11	Used to read temperature values in a miniroom
4	Sensor BH-1750	Used to read light intensity values in minirooms
5	Breadboard	Used to connect Arduino with other components
6	RTC	Used for current time readings.
7	Power Supply	Used to increase the voltage on the Arduino to activate components as well as actuators.
8	12V DC Fan	Used as a cooler in the miniroom space.
9	LED	Used as irradiation in a miniroom instead of sunlight in the room
10	Relay	Functions to turn on and off fans and LEDs

Table 2. Input & Output

Pin Arduino Uno	Sensors/Actuators
A4	SDA LCD, SDA RTC & SDA BH-1750
A5	SCL LCD, SCL RTC & BH-1750
D2	OUT DHT-11
D3	IN 3 (fan)
D4	IN 2 (LED)

### 2.1.2. System Flowchart

Flowchart is a diagram that reveals the flow of processing in a program and the relationship between processing (instructions) and other processing using certain symbols. In the flowchart for input hour condition values  $\geq 6$  and  $< 18$ , the value is a good lighting time for lettuce plants which is 1 hour/day. For input condition value  $< 30$ , is the recommended temperature value for lettuce plants which is in the range of 20-30°C. By installing setpoint hours  $\geq 6$  and  $< 18$  and  $< 30$ , the lettuce plants will always be met according to the recommended temperature and lighting requirements. The system flow chart is shown in Figure 2.

Figure 2 is the system flow chart. The process starts with sensor initialization and then continues with sensor readings. If the RTC reads the time  $\geq 6$  and  $< 18$  then the LED will turn on and will turn off if the RTC reads the time  $< 6$  and  $\geq 18$  then the LED will turn off. Then for the DHT-11 sensor, if the sensor reads a temperature value  $< 30$  then the fan will turn off and if the sensor reads a temperature value  $\geq 30$  then the fan will turn on. The BH-1750 sensor will display the light intensity reading in the miniroom. The 20x4 LCD will display the temperature value, lux value, fan condition, and TDS time on the system.

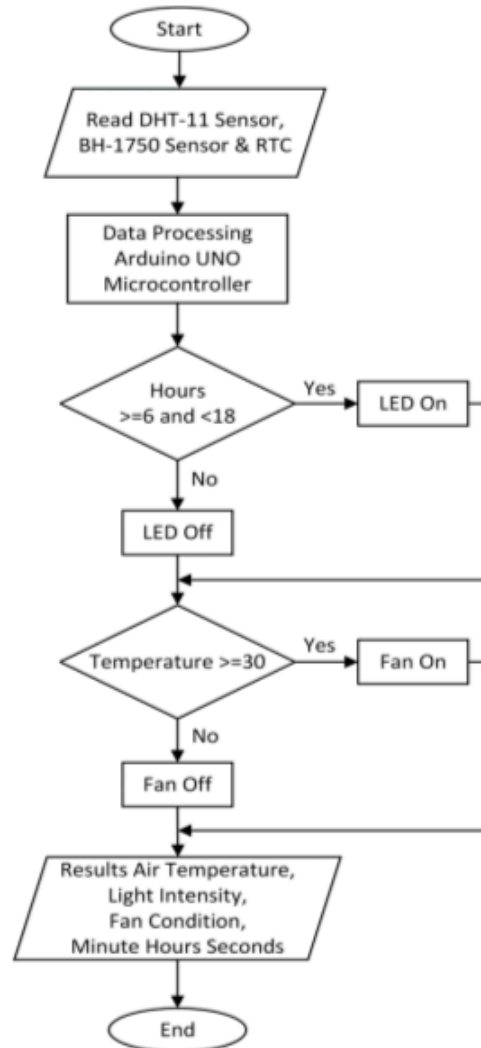

Figure 2. Flowchart

### 2.1.3. System Block Diagram

This research designs a system used to control temperature and lighting in hydroponic miniroom. The function of each in Figure 3 is explained as follows. This system uses a DHT-11 sensor that has a function to measure and detect the temperature value in the miniroom. The BH-1750 sensor is used to measure the value of light intensity. RTC is used as a realtime time. Arduino Uno microcontroller is used as a data processor and processor of input signals received by sensors. Relay is used to activate and deactivate the fan as a miniroom cooler and turn on and off the LED as a plant lighting in the miniroom. The Liquid Crystal Display (LCD) used is 20x4 as a data display of the results of the DHT-11 sensor value to measure room temperature, the results of the BH-1750 sensor value to measure the value of light intensity in the room and the results of the time reading from the RTC.

The DC12v fan functions as a cooler in the miniroom when the DHT-11 sensor detects the miniroom temperature <30 Celsius then the fan will stop, this condition is used to keep the temperature within good limits for plants. LED functions as a substitute for sunlight in indoor hydroponic systems. When the RTC reads the realtime hours >= 8 and hours <=6 then the LED will be OFF, this condition is used to meet the lighting needs of hydroponic plants, especially lettuce. Lettuce plants will grow optimally if the light received for 8-12 hours/day.

Temperature and Lighting Control of Deep Water Culture Hydroponic System in Automatic Miniroom Space

(Kurniawan Dwi Yulianto)

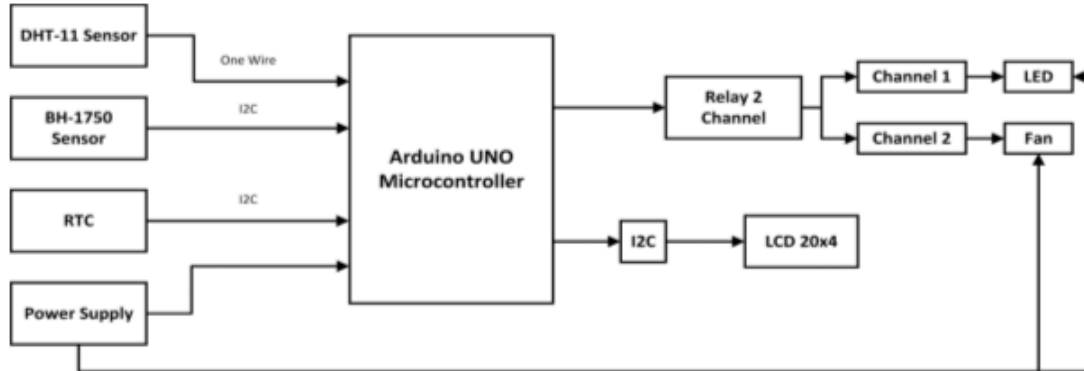

Figure 3. System block diagram

Figure 3 is the system block diagram design. The system block diagram generally consists of three parts, namely input, process and output. The controller part uses an Arduino Uno microcontroller that adapts to the input and output needs of the system being built. On the other hand, the input and output parts can be described as follows::

- a. Arduino input section:
  1. The DHT-11 sensor is used to determine the total dissolved solids in the nutrient liquid prepared in the hydroponic tub.
  2. BH-1750 sensor, used to read the water level in the hydroponic tub.
  3. RTC serves to add voltage or power to the Arduino to turn on other components and also serves to turn on the 12V pump.
  4. Power supply, used to add voltage to the Arduino to activate components and actuators
- b. Arduino output section:
  1. Relay module, functions as an automatic switch used to turn the 12V pump on and off.
  2. DC 12V fan serves as a cooling device in the miniroom room.
  3. LED functions as an illumination lamp in the miniroom to replace sunlight in the room
  4. 16x2 LCD serves to display the output value of the DHT-11 sensor, BH-1750 sensor, fan condition and RTC

## 2.2. Design of Components

The tool circuit is a circuit that is packaged together in a controller box. The circuit in the controller box is transparent with a size of 20×15×10 cm. In the box there are components namely Arduino uno, RTC, 20×4 LCD, and relay. The controller box is shown in Figure 4. The description of the components contained in the controller box is shown in Table 3.

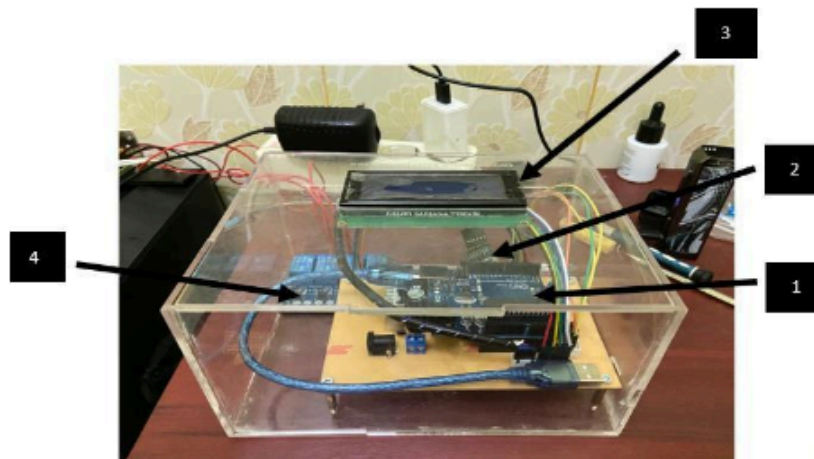

Figure 4. Controller box



**Table 3.** System circuit components

No	Component	Uses
1	Arduino Uno	As data processing.
2	RTC	Current time reading.
3	20x4 LCD	To display values from sensor readings, RTC
4	4 chanel relay	As a circuit breaker.

The miniroom has a fairly wide size with a length of 50 cm, a width of 35 cm, and a height of 35 cm as well. The miniroom contains components such as DHT-11 sensor, BH-1750 sensor, LED, and DC 12V fan. The inside view of the miniroom is shown in Figure 5. The components contained in the interior of the miniroom are shown in Table 4.

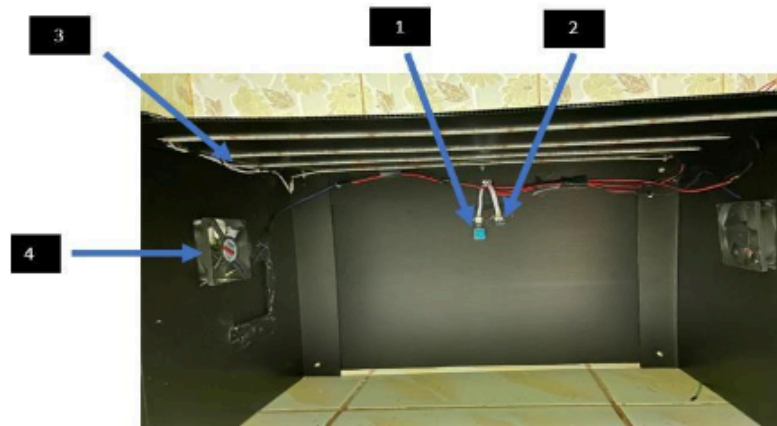
**Figure 5.** Inside view of the miniroom**Table 4.** Components in the miniroom

No	Component	Uses
1	Sensor DHT-11	Used to read values of temperature
2	Sensor BH-1750	Used to read light intensity values
3	LED strip	Used for irradiation in indoor sunlight replacement minirooms
4	12V DC Fan	Used as a cooler in a miniroom room.

### 2.3. System Testing

System testing must be carried out to determine the success rate of each tool mechanism during operation and to analyze whether there are problems with the tool mechanism. This research will conduct several system tests to get good final results, such as DHT-11 sensor testing, BH-1750 sensor testing, LCD testing, relay testing, RTC testing, actuator testing, overall system testing. The system is considered successful if the miniroom temperature that exceeds the normal limit value returns and the lighting can operate normally according to the specified lighting time.

### 3. RESULTS AND DISCUSSION

System testing is aimed at checking whether this system can operate in accordance with the analysis and plan. The test results are used for the purpose of improving system performance and are used together for the purpose of further development of this system. This test is only focused on testing the sensors used. The tests carried out include testing the DHT-11 sensor and the BH-1750 sensor. In testing the DHT-11 and BH-1750 sensors, the error values obtained will be calculated and compared with standard measuring instruments so that the results of the calibration get realistic and accurate values in accordance with the standard measuring instruments used so that the sensors can be applied in the Hydroponic system. Calculation of the error value of the sensor can be calculated using the formulas of Equations (1) and (2).

$$\text{Difference} = |\text{Reference Value} - \text{Value of Sensor}| \quad (1)$$

$$\text{Percentage error} = \frac{|\text{Difference}|}{|\text{Reference Value}|} \times 100\% \quad (2)$$

### 3.1. DHT-11 Sensor Testing

DHT-11 sensor testing is done to ensure the sensor is running properly or not. The sensor is used to detect the temperature in the miniroom. The DHT-11 sensor has a pin out component to flow a digital signal into the circuit so that it can read the air temperature value. The results of the sensor reading need a sensor calibration process that is useful for getting the difference and error between the sensor and the measuring instrument used. The results of the calibration get a realistic and accurate value in accordance with the standard measuring instrument used so that the sensor can be applied in the Hydroponic system. Calculation of the error value of the sensor can be calculated using Equations (1) and (2). The calculation results of the difference and the temperature error value are obtained as in Table 5. The graph shown in Figure 6 and the result of Table 5.

Table 5. DHT-11 sensor error values

N	DHT-11	Thermometer Digital	Difference	Error Value
1	31.1	31.4	0.3	0.95%
2	31.2	31.4	0.2	0.63 %
3	30.6	30.9	0.3	0.97 %
4	30.7	31.2	0.5	1.60 %
5	30.9	31.5	0.6	1.90 %
6	30.1	30.6	0.5	1.63 %
7	30.2	30.8	0.6	1.94 %
8	30.5	31	0.5	1.61 %
9	31	31.6	0.6	1.89 %
10	30.8	31.2	0.4	1.28 %
Average Error				1.44 %

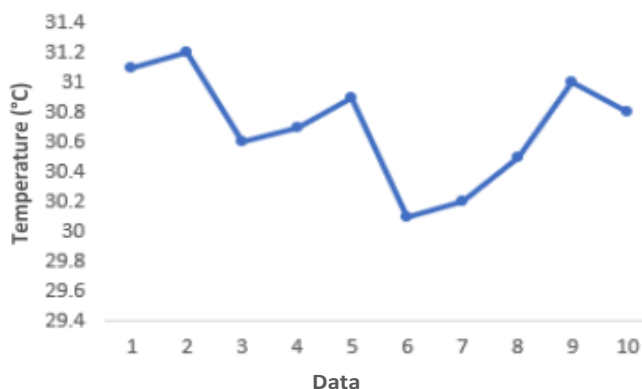

Figure 6. Temperature graph

Table 5 is the result of calculating the error value of the DHT-11 sensor test. The error value is obtained from the comparison between the readings from the DHT-11 sensor and a standard measuring instrument, namely a digital thermometer and an average error value of 1.44% is obtained. The test results show that the interval of the test results is not the same as the interval of the calculation results, with the error rate ranging from 0.63% to 1.94%. Based on the DHT-11 sensor datasheet, the temperature measurement limit is 0-50 °C with a large error of  $\pm 2$  °C.

### 3.2. Testing of BH-1750 Sensor

Testing the BH-1750 sensor is done to ensure the sensor is running properly or not. The sensor is used to detect the light intensity in the miniroom. The results of the sensor readings need to be carried out a sensor calibration process which is useful for getting the difference and error between the sensor and the measuring instrument used. The results of the calibration get realistic and accurate values in accordance with the standard measuring instruments used so that the sensor can be applied in the Hydroponic system. The error value of the sensor can be calculated using Equations (1) and (2). The calculation results of the difference and error value of light intensity are obtained as in Table 6. The graphical data results are shown in Figure 7 which is the result of Table 6.

Table 6 is the result of calculating the error value of the BH-1750 sensor test. The error value is obtained from the comparison between the readings from the BH-1750 sensor and a standard measuring instrument, namely a digital thermometer and an average error value of 2.48% is obtained. The test results show that the

interval of the tool test results is not the same as the interval of the calculation results, with the error rate ranging from 1.42% to 19.51%. Based on the BH-1750 sensor datasheet, wide range and high resolution.

**Table 6.** Error value of BH-1750 sensor

N <sup>6</sup>	Sensor BH1750	Lux meter	Difference	Error
1	225.83	233	7.17	3.08 %
2	260.83	256	4.83	1.89 %
3	261.67	258	3.67	1.42 %
4	14.17	12	2.17	18.08 %
5	137.5	149	11.5	7.72 %
6	70.83	88	17.17	19.51 %
7	111.67	117	5.33	4.56 %
8	235.83	208	27.83	13.38 %
9	124.17	115	9.17	7.97 %
10	72.5	62	10.5	16.94 %
Average Error Value				2.48 %

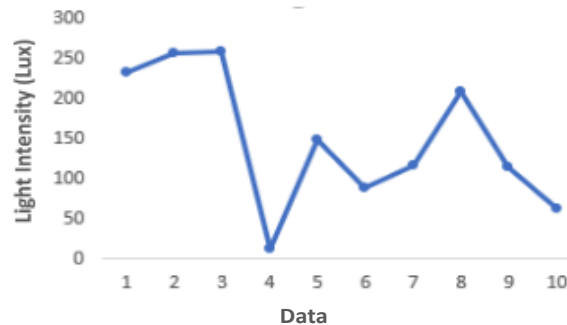

**Figure 7.** Light intensity graph

### 3.3. Test Results of the Overall Control System

Overall system testing, measurement results from sensors and relay status sent by Arduino Uno are processed and will be displayed on the 20×4 LCD. Settings on the Arduino Uno controller hardware system are used to set the maximum limit and minimum limit of the sensor. The value limit set in this system is for the DHT-11 sensor which has a value limit of >30 °C. Meanwhile, the RTC has a reading limit of >30 °C. While for the RTC has a limit of RTC readings (hours >= 6 & & hours < 18) WIB. Table 7 shows the results of sensor readings in the form of fans and LEDs. The overall control system test results are shown in Table 7.

**Table 7.** Test results of the overall control system

No	Waktu Data Retrieval Hour	Sensor Value		Control Status	
		Temperature (°C)	Light Intensity (lx)	Fan Exhaust	LED
1	05.00	29.10	0	OFF	OFF
2	06.00	29.10	0	OFF	OFF
3	07.00	29.60	620.00	OFF	ON
4	08.00	29.60	620.00	OFF	ON
5	09.00	30.00	620.00	OFF	ON
6	10.00	30.00	620.00	OFF	ON
7	11.00	30.00	620.00	OFF	ON
8	12.00	30.50	620.00	ON	ON
9	13.00	30.50	620.00	ON	ON
10	14.00	30.50	620.00	ON	ON
11	15.00	30.90	620.00	ON	ON
12	16.00	30.90	620.00	ON	ON
13	17.00	31.30	620.00	ON	ON
14	18.00	31.30	620.00	ON	ON
15	19.00	30.90	0	ON	OFF
16	20.00	29.90	0	OFF	OFF

Table 7 is the result of testing the entire system. In testing the DHT-11 sensor, realtime testing is carried out with measurements in the indoor room. The DHT-11 sensor reads the initial value of 29.10 °C, the condition the fan turns off. At 12.00 the DHT-11 sensor reads a temperature value of 30.50 °C, the condition is the fan

is on. With this value, the system can be said to be successful because the fan successfully starts when the temperature value read is above 30.00 °C. RTC testing is done by setting the clock on a laptop to make sure the RTC can work properly or not. Table 7 shows the initial time of RTC reading at 05.00 WIB, the condition of the LED is off. At 06.00 WIB the LED is on. This value means that the system can be said to be successful because the LED successfully lives when the time read is at 06.00-18.00 WIB.

#### 4. CONCLUSIONS

Based on the results of testing the entire system, it can be concluded that the system made can control the temperature using a fan and lighting using LEDs works in accordance with predetermined requirements. The DHT-11 sensor has a fairly good accuracy level of  $\pm 2$  °C in the datasheet with an error value of 1.44%. As for the BH-1750 sensor has an error value of 2.48%, this result is quite good because according to the datasheet on the BH-1750 sensor has an error value of  $\pm 20\%$  so that it can be applied to the system. The use of RTC as a lighting timer can run well and successfully.

#### REFERENCES

- [1] W. Iswardani, "Hydroponic Vegetable Production Planning at Plantation Parung Farm Bogor," *AKADEMIK: Jurnal Mahasiswa Sain & Teknologi*, vol. 1, no. 1, pp. 8-15, 2021, <https://ojs.pseb.or.id/index.php/jmst/article/view/1116>.
- [2] S. Ragaveena, A. S. Edward, and U. Surendran, "Smart controlled environment agriculture methods: A holistic review," *Reviews in Environmental Science and Bio/Technology*, vol. 20, no. 4, pp. 887-913, 2021, <https://doi.org/10.1007/s11157-021-09591-z>.
- [3] A. Hamza, R. E. Abdelraouf, Y. I. Helmy, and S. M. M. El-Sawy, "Using deep water culture as one of the important hydroponic systems for saving water, mineral fertilizers and improving the productivity of lettuce crop," *International Journal of Health Sciences*, vol. 6, pp. 2311-2331, 2022, <https://doi.org/10.53730/ijhs.v6nS9.12932>.
- [4] M. Majid *et al.*, "Evaluation of hydroponic systems for the cultivation of Lettuce (*Lactuca sativa* L., var. Longifolia) and comparison with protected soil-based cultivation," *Agricultural Water Management*, vol. 245, p. 106572, 2021, <https://doi.org/10.1016/j.agwat.2020.106572>.
- [5] D. M. R. Dungca *et al.*, "Innovating Green Wall: A Sustainable Way of Enhancing the Vertical Planting System," *2021 IEEE 13th International Conference on Humanoid, Nanotechnology, Information Technology, Communication and Control, Environment, and Management (HNICEM)*, pp. 1-6, 2021, <https://doi.org/10.1109/HNICEM54116.2021.9731929>.
- [6] G. T. Freschet *et al.*, "A starting guide to root ecology: strengthening ecological concepts and standardising root classification, sampling, processing and trait measurements," *New Phytologist*, vol. 232, no. 3, pp. 973-1122, 2021, <https://doi.org/10.1111/nph.17572>.
- [7] M. V. Luneva *et al.*, "Hotspots of dense water cascading in the Arctic Ocean: Implications for the Pacific water pathways," *Journal of Geophysical Research: Oceans*, vol. 125, no. 10, p. e2020JC016044, 2020, <https://doi.org/10.1029/2020JC016044>.
- [8] J. A. Thies, "Grafting for managing vegetable crop pests," *Pest Management Science*, vol. 77, no. 11, pp. 4825-4835, 2021, <https://doi.org/10.1002/ps.6512>.
- [9] T. Hooks, L. Sun, Y. Kong, J. Masabni, and G. Niu, "Effect of Nutrient Solution Cooling in Summer and Heating in Winter on the Performance of Baby Leafy Vegetables in Deep-Water Hydroponic Systems," *Horticulturae*, vol. 8, no. 8, p. 749, 2022, <https://doi.org/10.3390/horticulturae8080749>.
- [10] Z. Wang, L. Yue, O. P. Dhankher, B. Xing, "Nano-enabled improvements of growth and nutritional quality in food plants driven by rhizosphere processes," *Environment International*, vol. 142, p. 105831, 2020, <https://doi.org/10.1016/j.envint.2020.105831>.
- [11] G. S. Colares *et al.*, "Floating treatment wetlands: A review and bibliometric analysis," *Science of the Total Environment*, vol. 714, p. 136776, 2020, <https://doi.org/10.1016/j.scitotenv.2020.136776>.
- [12] J. T. Spangler, D. J. Sample, L. J. Fox, J. S. Owen Jr, and S. A. White, "Floating treatment wetland aided nutrient removal from agricultural runoff using two wetland species," *Ecological Engineering*, vol. 127, pp. 468-479, 2019, <https://doi.org/10.1016/j.ecoleng.2018.12.017>.
- [13] S. Dwiratna, K. Amaru, and M. A. Nanda, "The modified hydroponic kit based on self-fertigation system designed for remote areas," *Horticulturae*, vol. 8, no. 10, p. 948, 2022, <https://doi.org/10.3390/horticulturae8100948>.
- [14] G. Pennisi *et al.*, "Unraveling the role of red: blue LED lights on resource use efficiency and nutritional properties of indoor grown sweet basil," *Frontiers in plant science*, vol. 10, p. 305, 2019, <https://doi.org/10.3389/fpls.2019.00305>.
- [15] L. D. Van *et al.*, "PlantTalk: A smartphone-based intelligent hydroponic plant box," *Sensors*, vol. 19, no. 8, p. 1763, 2019, <https://doi.org/10.3390/s19081763>.
- [16] D. K. P. Aji, U. Nurhasan, R. Arianto, and O. D. Triswidrananta, "Smart ecosystem for hydroponic land in the hydroponic farmers group guided by CSR PT. Otsuka Indonesia as an improved quality and quantity of harvest results," *In IOP Conference Series: Materials Science and Engineering*, vol. 1073, no. 1, p. 012030, 2021, <https://doi.org/10.1088/1757-899X/1073/1/012030>.
- [17] R. Paradiso and S. Proietti, "Light-quality manipulation to control plant growth and photomorphogenesis in greenhouse horticulture: The state of the art and the opportunities of modern LED systems," *Journal of Plant Growth Regulation*, vol. 41, no. 2, pp. 742-780, 2022, <https://doi.org/10.1007/s00344-021-10337-y>.
- [18] R. Lippmann, S. Babben, A. Menger, C. Delker, M. Quint, "Development of wild and cultivated plants under global warming conditions," *Current Biology*, vol. 29, no. 24, pp. R1326-R1338, 2019, <https://doi.org/10.1016/j.cub.2019.10.016>.

- [19] R. J. Lee, S. R. Bhandari, G. Lee, and J. G. Lee, "Optimization of temperature and light, and cultivar selection for the production of high-quality head lettuce in a closed-type plant factory," *Horticulture, Environment, and Biotechnology*, vol. 60, no. 2, pp. 207-216, 2019, <https://doi.org/10.1007/s13580-018-0118-8>.
- [20] R. Sutulienė, K. Laužikė, T. Pukas, and G. Samuolienė, "Effect of light intensity on the growth and antioxidant activity of sweet basil and lettuce," *Plants*, vol. 11, no. 13, p. 1709, 2022, <https://doi.org/10.3390/plants11131709>.

#### AUTHOR BIOGRAPHY



**Kurniawan Dwi Yulianto** is an student in Department of Electrical Engineering at Universitas Ahmad Dahlan, Yogyakarta, Indonesia.



**Riky Dwi Puriyanto** is a Lecturer in the Department of Electrical Engineering, Faculty of Technology at Universitas Ahmad Dahlan, Yogyakarta, Indonesia.