

Human Movement Detection System Based On The Internet Of Things

Nur Ifan Syah¹, Sunardi²

^{1,2}S1 Electrical Engineering Study Program, Faculty of Industrial Technology, Ahmad Dahlan University Yogyakarta

ARTICLE INFORMATION

Article History:

Submitted 15 June 2024

Revised 15 June 2024

Accepted

Keywords:

**PIR sensors;
NodeMCU ESP8266;
Internet Of Things;**

Corresponding Author:

Sunardi
Department of Electrical
Engineering, University
Ahmad Dahlan, Yogyakarta,
Indonesia.
Email/Email:
sunardi@te.uad.ac.id

ABSTRACT

This research refers to making an IoT-based movement system tool. This system is used to calculate the number of human movements entering a room and also people leaving the room. In this study, a Passive Infrared Receiver (PIR) sensor is used to detect the movement of people when entering a room. The sensor will trigger a calculation of the number of people passing through the device, equipped with NodeMCU ESP 8266 as a microcontroller, with NodeMCU ESP 8266 it is more efficient to connect to the WiFi module on the Internet of Things system without the need for other modules. The tool is also equipped with an LED light as a notification of movement, an indicator buzzer if the room is fully filled, and there is also a Liquid Crystal Display (LCD) which is used to display the number of human movements entering and leaving the room, as well as the people who are in the room. The sensitivity of the PIR sensor depends on the distance of the object to the sensor. The research is running well. Notifications from the LED light go according to their duties, if someone enters the room then LED 1 will light ON, and if someone leaves the room then LED 2 will light ON. The results of the application in detecting objects of people or visitors one by one are conditioned based on walking movements and based on a person's height posture from 150 cm to 170 cm the accuracy of the object is accurate, because the distance from the object to the The tool is not too far so the tool can easily detect its movement.

This work is licensed under a Creative Commons Attribution-Share Alike 4.0



Citation Document:

Nur Ifan Syah and Sunardi, "Internet Of Things Based Movement System" Undergraduate Scientific Bulletin of Electrical Engineering, vol. 3, no. 1, pp. xx-xx, 2021. DOI: [10.12928/biste.v3i1.xxx](https://doi.org/10.12928/biste.v3i1.xxx)

1. INTRODUCTION

Developments in the world of science and technology are becoming more and more sophisticated day by day, providing benefits and very positive impacts on human activities in everyday life. Technological developments must be balanced by utilizing the human resources we have, if we cannot utilize them then we will not be able to keep up with developments in this increasingly advanced era [1]. Nowadays humans are supported by various technologies ranging from motorized vehicles with intelligent systems, intelligent wheelchairs, sophisticated communication devices, to smart homes that can be seen and controlled remotely using an intelligent system called the Internet of Things [2].

One of the technologies most often used in everyday life is home security which usually uses smart home technology which is equipped with the help of a camera as a means to see the condition of the house or room when it is unoccupied, which is one solution in the security process [3].

Monitoring the condition of the house can be done by using a tool equipped with a movement detector where the tool will function to detect movement passing through the tool and will automatically count movements entering the room or leaving the room [4],[5] Apart from being applicable to smart homes, this tool can be applied to homes, offices, stadiums, restaurants and also places that require visitor data. This data can be seen in real time on the LCD screen provided and can be viewed using an application that has been connected to the device to be accessed via smartphone.

The development of increasingly sophisticated technology should make all human work easier, from helping to doing work that is usually done by humans in general [6]-[9]. Sometimes people still do not support the existence of tools that can help and make all human work easier, preferring to use the help of other people rather than innovations that are easier and more practical [10].

Sometimes the main reason for not supporting technologically advanced tools is the unaffordable price factor among society in general, even though if we calculate it, sometimes it is more expensive to use human labor which must be paid every month [11],[12]. If you use a tool, the costs are large at the start but there are no costs that have to be paid every month. This automatic visitor counting tool is actually a very necessary tool for entrepreneurs who have business premises such as restaurants or buildings that are used for various kinds of events [13],[14]

This movement detection tool is based on the internet of things (IOT) which requires an internet network that is always connected to the tool to be able to continue operating. Internet network access in Indonesia is said to be not yet completely stable and there are still many areas that cannot access the internet properly, such as in remote areas [15]. Still not reachable, it needs to be considered more carefully to be able to operate the tool so that it can be used in various areas and makes it easier for users.

Apart from the internet network needed, of course there must be a tool that can operate the internet, namely a smartphone. This tool requires a smartphone to be able to operate the tool's working system which can control and monitor all situations generated by the tool [16].

In this detection tool there are two PIR sensors which function to detect all types of movement, the distance that the sensors can reach is not too far, around 1-4 meters, but the PIR sensor is very sensitive to all types of movement [17]. The detection equipment is not yet equipped with a camera so it cannot be certain that the movement originates from humans or from other objects [18]. Component devices experience their own problems, such as the PIR sensor which is too sensitive to all types of movement, so the device cannot determine where the resulting movement is coming from.

An internet of things based movement tool is installed around the door of the house to make it easier for the PIR sensor to be able to detect all types of movement from the incoming PIR sensor and the outgoing PIR sensor. The tool is installed at a height of 100 meters above the floor surface due to minimizing the resulting errors [19].

2. METHODS

The research that will be carried out focuses more on creating an IoT-based movement system tool to identify and count the number of human movements entering and leaving the room. The system built uses the NodeMCU ESP8266 as a more efficient microcontroller to be able to connect to the WiFi module in the

IoT system without requiring other modules [20]. The tool is also equipped with a Light Emitting Diode (LED) as notification of movement, an indicator buzzer if the room is fully occupied and there is a Liquid Crystal Display (LCD) which is used to display the number of human movements entering and leaving the room, as well as the number of people present room [21].

The way this tool works is quite easy, starting from reading the movements made by a motion sensor using two PIR sensors to be placed at the room entrance and room exit. The PIR sensor will detect movement and then carry out the tasks properly which have been programmed and set by the NodeMCU ESP8266 as a microcontroller to control the program that has been loaded on the microcontroller. If movement is detected entering the room, the sensor will send data which is displayed on the LCD in real time and is indicated by a lit LED as an indication that there is movement entering the room [22]. On the other hand, if there is movement past the exit, the PIR sensor located at the exit will send an indication of exit movement and automatically the screen display on the LCD will decrease and the LED light will turn on. There are tools and materials used in the research as in Table 1.

Table 1. Research Tools

No	Device	Utility
1	PIR sensors	Data input (Research object)
2	NodeMCU ESP8266	Microcontroller
3	LED lights	Outputs
4	Buzzers	Outputs
5	LCD i2c 16x2	Display data
6	Smartphones	Data monitoring

There is bSome of the software used to support research is shown in Table 2. The software used is divided into test software, operating systems, and analysis tools.

Table 2. Supporting Software

No	Supporting devices	Utility
1	Arduino IDE	Software testing
2	Fritzing	Network design tools
3	Blynk	Data monitoring

The system design of this tool consists of component design or hardware design and also wiring diagram shown in Figure 1,2 and Figure 3.



Figure 1. Hardware Design



Figure 2. Device installed on the door

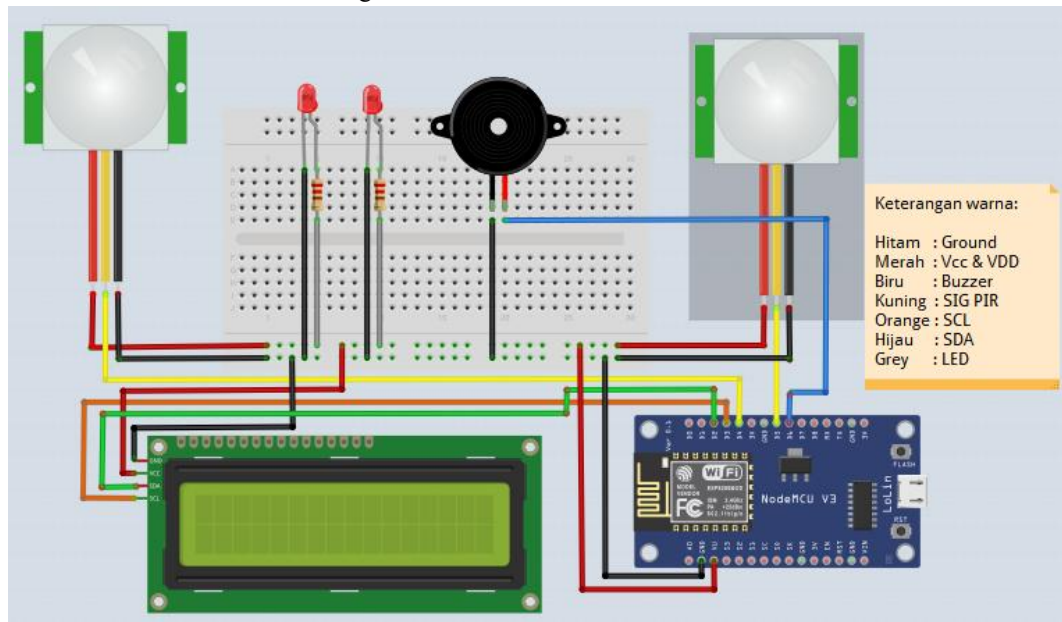

Figure 3. Wiring diagram

The river water level monitoring system based on IoT can develop by using block diagram and flowchart in Figure 4 and Figure 5.

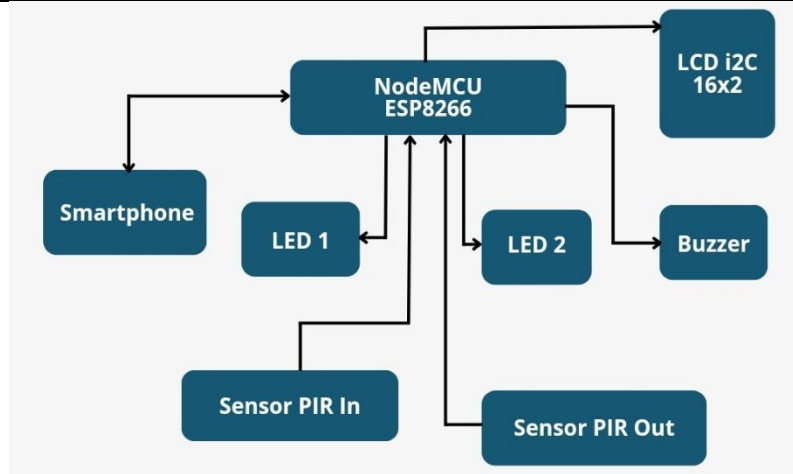

Figure 4. Block diagram

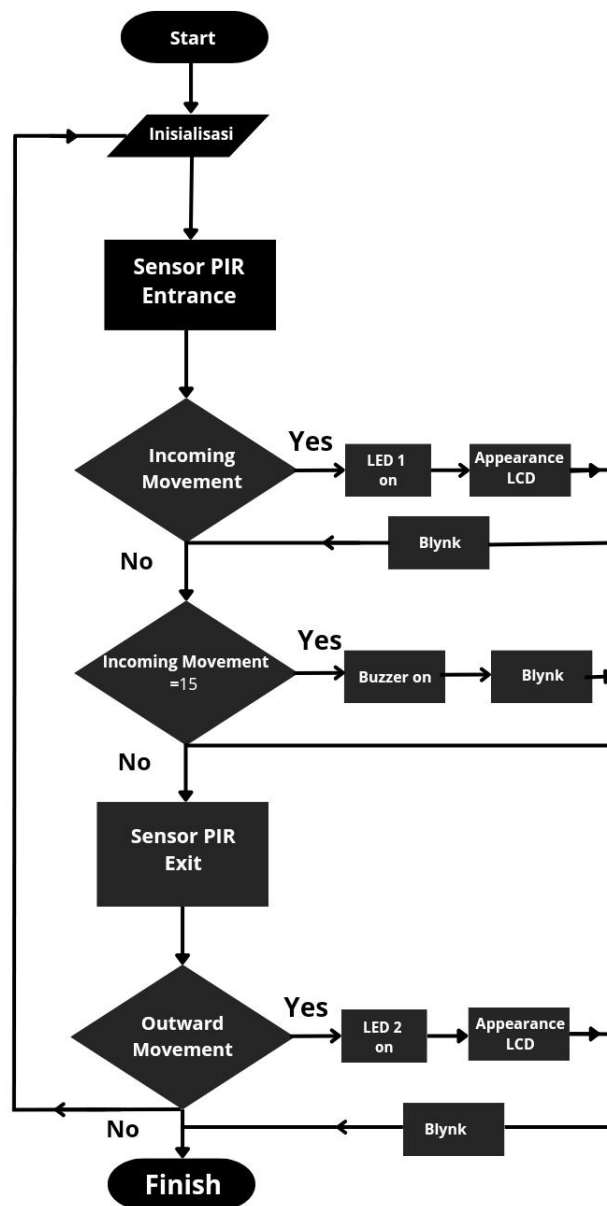

Figure 5. System flowchart

3. RESULTS AND DISCUSSION

The aim of testing and checking tools is to minimize errors that occur in the tools being made, such as testing the components installed in the circuit, such as the ESP8266 NodeMCU, LED testing, buzzer testing, and PIR sensor testing.

3.1 PIR Sensor Testing

This test was carried out because the PIR sensor is one of the main components of the tool being made. This test aims to determine the usefulness of the PIR sensor. The experimental results can be seen in Figure 6.

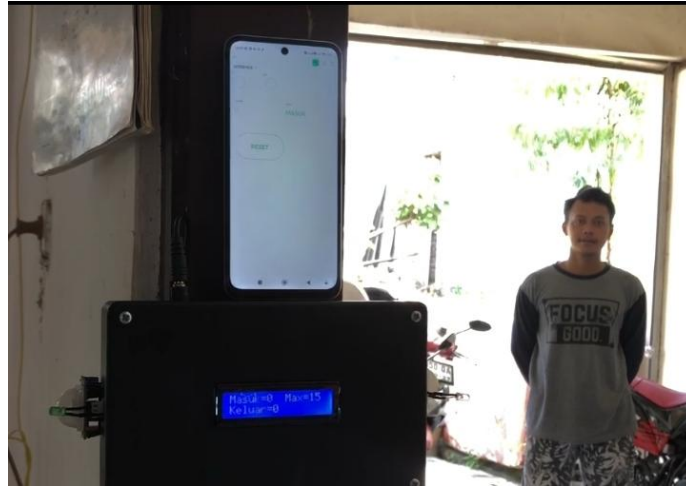

Figure 6. Human objects are not detected

3.2.LED Testing

In the tool that is made there are two LED monitoring lights to find out if there is movement entering the room and leaving the room, the LED will send a signal or the light will turn on as in Figure 7 and Figure 8.



Figure 7. The entrance LED lights up



Figure 8. The exit LED is on

3.3. Buzzer Testing

This tool has determined the maximum limit for movements entering the room, namely 15 movements entering, which is indicated by a buzzer sound every time 15 movements are detected. The aim of creating this tool is to make it easier for the owner of a place to be able to count the number of visitors in his area without having to count manually with the help of someone. The test results can be seen in Table 3

Table 3. Buzzer test results

Test	Maximum limit	Detected	Buzzers
1	15 people	15 people entered	Active
2	15 people	14 people entered	No
3	15 people	13 people entered	No
4	15 people	12 people entered	No
5	15 people	11 people entered	No
6	15 people	10 people entered	No
7	15 people	9 people entered	No
8	15 people	8 people entered	No
9	15 people	7 people entered	No
10	15 people	6 people entered	No

The maximum notification limit experiment in the form of a buzzer sound has been running according to the application flow when the number of visitors in the room exceeds the specified maximum limit as in Figure 9.



Figure 9. Tool reaches maximum limit

3.4. Tool Testing

This system focuses more on the movements a person makes towards the installed equipment. When movement entering the room is detected by the PIR sensor, the system will start counting. Next, the system will count how many people in the room have detected movement from the system at the entrance. The sensor will detect any type of movement if the attached tool is located in an ideal position and is easy to reach. It looks like in Figure 10 and Figure 11.



Figure 10. The tool can detect entry



Figure 11. The tool has detected leaving the room

The tool can detect all types of movement, movement in and out of the room, other components such as buzzers, LEDs and PIR sensors have worked according to the desired system, so the tool has been tested 9 times. As seen in Table 4.

Table 4. Tool experiments

No	Enter PIR Sensor 1	Go out PIR Sensor 2	LED 1	LED 2	Buzzers	Amount inside
1	1 Sign in	0 Exit	Light up	No	No	1 person
2	2 Sign in	0 Exit	Light up	No	No	2 persons
3	3 Sign in	0 Exit	Light up	No	No	3 people
4	4 Sign in	1 Exit	Light up	Light up	No	3 people
5	5 Sign in	0 Exit	Light up	No	No	5 people
6	1 Sign in	1 Exit	Light up	Light up	No	0 people
7	14 Sign in	5 Exit	Light up	Light up	No	9 people

8	15 Sign in	0 Exit	Light up	No	Sound	15 people
9	15 Sign in	1 Exit	No	Light up	No	14 people

4. Conclusion

The tool has been successfully designed and manufactured as expected, such as being able to detect the movement of a person entering and leaving the room, has been implemented around the door of the house and has been installed in a place that is easily accessible by the PIR sensor. The tool can detect objects, people one by one, conditioned at a distance of 1-4 meters accurately, while at a distance of 5 meters no objects are detected, and has an angle range of 120°. Notification in the form of a buzzer sound has run according to the desired conditions, when the tool If it detects 15 movements, the buzzer will sound.

REFERENCES

- [1] Q. Yuan and W. Zhang, "Design of home burglar alarm based on MCU and PIR sensors," 202 IEEE 3rd International Conference on Power, Electronics and Computer Applications (ICPECA), pp. 1677-1680, 2023 <https://doi: 10.1109/ICPECA56706.2023.10076018>
- [2] I. Ciuffreda, S. Casaccia and G. M. Revel, "Localization of Older People in an Indoor Scenario: A Measurement System Based on PIR Sensors Installed in a Social Robot," 2023 IEEE International Workshop on Metrology for Living Environment (MetroLivEnv), pp. 208-212, 2023 <https://doi: 10.1109/>
- [3] D. Septyadi and S. Mandala, "Analysis of Home Security System Design Based on 4 PIR Sensors Using Deep Learning Method," 2023 International Conference on Data Science and Its Applications (ICoDSA), Bandung, Indonesia, pp. 181-186, 2023. <https://doi: 10.1109/ICoDSA58501.2023.10277453>.
- [4] B. N. Gerald Ergi and S. Mandala, "PIR Sensor-Based Intelligent Home Security System Design Analysis Using Machine Learning Methods," 2023 International Conference on Data Science and Its Applications (ICoDSA), Bandung, Indonesia, pp. 175-180, 2023 <https://doi: 10.1109/ICoDSA58501.2023.10277399>
- [5] S. Gaikwad and S. N. Pawar, "Enhanced Accident Detection System Using IOT," 2023 IEEE International Conference on Blockchain and Distributed Systems Security (ICBDS), pp. 1-6, 2023 <https://doi: 10.1109/ICBDS58040.2023.10346404>
- [6] R. Rishab et al., "Cloud-Controlled Dynamic Smart Street Lighting System," 2023 International Conference on Next Generation Electronics (NEleX), pp. 1-5, 2023 <https://doi: 10.1109/NEleX59773.2023.10420861>
- [7] M. Pillewan, R. Agrawal, N. Wyawahare and L. Thakare, "Development of Domestic Animals Shelter Environment Monitoring System using Internet of Things (IoT)," 2023 International Conference on Sustainable Computing and Smart Systems (ICSCSS), Coimbatore, pp. 972-976, 2023 <https://doi: 10.1109/ICSCSS57650.2023.10169332>
- [8] H. Garg and M. Dave, "Securing IoT Devices and SecurelyConnecting the Dots Using REST API and Middleware," 2019 4th International Conference on Internet of Things: Smart Innovation and Usages (IoT-SIU), pp. 1-6, 2019 <https://doi: 10.1109/IoT-SIU.2019.8777334>.
- [9] S. S. Siddula, P. Babu and P. C. Jain, "Water Level Monitoring and Management of Dams using IoT," 2018 3rd International Conference On Internet of Things: Smart Innovation and Usages (IoT-SIU), pp. 1-5, 2018 <https://doi: 10.1109/IoT-SIU.2018.8519843>.
- [10] D. Balsamo, M. Magno, K. Kubara, B. Lazarescu and G. V. Merrett, "Energy Harvesting Meets IoT: Fuelling Adoption of Transient Computing in Embedded Systems," 2019 IEEE 5th World Forum on Internet of Things (WF-IoT), pp. 413-417, 2019 <https://doi: 10.1109/WF-IoT.2019.8767302>.
- [11] M. S. Gayathri, A. N. Ravishankar, S. Kumaravel and S. Ashok, "Battery Condition Prognostic System using IoT in Smart Microgrids," 2018 3rd International Conference On Internet of Things: Smart Innovation and Usages (IoT-SIU), pp. 1-6, 2018 <https://doi: 10.1109/IoT-SIU.2018.8519859>.
- [12] A. Elewah, W. M. Ibrahim, A. Rafikl and K. Elgazzar, "ThingsDriver: A Unified Interoperable Driver for IoT Nodes," 2022 International Wireless Communications and Mobile Computing (IWCMC), pp. 877-882, 2022 <https://doi: 10.1109/IWCMC55113.2022.9824989>.
- [13] N. Maleki et al., "DynaSens: Dynamic Scheduling for IoT Devices Sustainability," 2022 International Conference on Broadband Communications for Next Generation Networks and Multimedia Applications (CoBCom), pp. 1-7, 2022 <https://doi: 10.1109/CoBCom55489.2022.9880629>.
- [14] A. A. S. AlQahtani, H. Alamleh and B. Al Smadi, "IoT Devices Proximity Authentication In Ad Hoc Network Environment," 2022 IEEE International IOT, Electronics and Mechatronics Conference (IEMTRONICS), pp. 1-5, 2022 <https://doi: 10.1109/IEMTRONICS55184.2022.9795787>.
- [15] A. E. Khaled, M. Ashfaq and S. P. Suresh, "E-IoT: Emulator to Develop and Test IoT Application," 2022 IEEE 8th World Forum on Internet of Things (WF-IoT), pp. 1-6, 2022 <https://doi: 10.1109/WF-IoT54382.2022.10152067>.
- [16] A. K. Dudhpachare, T. V. Kuthe, C. V. Lalke, N. P. Wyawahare, R. Agrawal and P. Daigavane, "Process of RO's Waste Water Reuse & Water Management in Society by Using IOT Automation," 2022 International Conference on Applied Artificial Intelligence and Computing (ICAAIC), pp. 1546-1550, 2022 <https://doi: 10.1109/ICAAIC53929.2022.9792805>.
- [17] S. Bansal and V. K. Tomar, "Challenges & Security Threats in IoT with Solution Architectures," 2022 2nd International Conference on Power Electronics & IoT Applications in Renewable Energy and its Control (PARC), pp. 1-5, 2022 <https://doi: 10.1109/PARC52418.2022.9726660>.
- [18] K. D. Ballal, R. Singh, L. Dittmann and S. Ruepp, "Experimental Evaluation of Roaming

-
- Performance of Cellular IoT Networks," 2022 Thirteenth International Conference on Ubiquitous and Future Networks (ICUFN), pp. 386-391, 2022 <https://doi: 10.1109/ICUFN55119.2022.9829590>.
- [19] S. K. Vishwakarma, P. Upadhyaya, B. Kumari and A. K. Mishra, "Smart Energy Efficient Home Automation System Using IoT," 2019 4th International Conference on Internet of Things: Smart Innovation and Usages (IoT-SIU), pp. 1-4, 2019 <https://doi: 10.1109/IoT-SIU.2019.8777607>
- [20] M. M. A. Al Momani and P. S. Puttaswamy, "Development of Secured Authentication Contract Communication Network Protocol for IoT Environment," 2022 Fourth International Conference on Emerging Research in Electronics, Computer Science and Technology (ICERECT), pp. 1-6, 2022 <https://doi: 10.1109/ICERECT56837.2022.10060005>.
- [21] Z. Tang, J. Fan, W. Chen, Y. Li, M. G. Mohamed and R. Li, "Optimal thermal design of LED automotive headlamp with the response surface method," 2019 16th China International Forum on Solid State Lighting & 2019 International Forum on Wide Bandgap Semiconductors China (SSLChina: IFWS), pp. 214-219, 2019 <https://doi: 10.1109/SSLChinaIFWS49075.2019.9019807>.
- [22] D. Banerjee, P. Banerjee, B. Goswami and R. Ghosh, "Deriving an electrical model of a two terminal piezoelectric buzzer from its impedance response," 2018 IEEE Applied Signal Processing Conference (ASPCON), pp. 114-118, 2019 <https://doi: 10.1109/ASPCON.2018.8748588>.